

MONTEREY COUNTY PLANNING COMMISSION

Meeting: October 9, 2013 Time: 9:00 A.M.	Agenda Item No.: 2
Project Description: CONTINUED FROM SEPTEMBER 11, 2013. A Public Hearing to : 1) Consider a Technical Addendum to the Environmental Impact Report for the Santa Lucia Preserve (EIR 94-005) prepared for the approval of Combined Development Permit No. PLN080350; and 2) Consider a three-year extension of Combined Development Permit No. PLN080350 consisting of: a) Administrative Permit to allow the construction of a 6,230 square foot two-story single family dwelling with an attached 1,000 square-foot three-car garage, a 1,055 square-foot barn, an 800 square foot swimming pool, 15 garden walls totaling 580 linear feet in the "S" (Site Plan Review) zoning district; b) Administrative Permit to allow an 840 square foot detached accessory dwelling unit with a 253 square-foot covered terrace; and c) Use Permit to allow the removal of 28 oak trees (5 of the oak trees to be re-located on-site); and grading consisting of 240 cubic yards of cut and 75 cubic yards of fill; and d) a Design Approval.	
Project Location: 8 Goodrich Trail, Carmel	APN: 239-102-021-000
Planning File Number: PLN130509	Owner: Attorneys Benefits Corporation Agent: Paul and Nancy Sallaberry
Planning Area: Carmel Valley Master Plan	Flagged and staked: No
Zoning Designation: : "RG/10-D-S-RAZ" or Rural Grazing, 10 acres per unit with Design Control, Site Plan Review, and Residential Allocation zoning district overlays	
CEQA Action: Consider the Addendum to the Environmental Impact Report for the Santa Lucia Preserve (EIR 94-005)	
Department: RMA - Planning	

RECOMMENDATION:

Staff recommends that the Planning Commission adopt a resolution (**Exhibit A**) to:

- 1) Consider the Addendum to the Environmental Impact Report for the Santa Lucia Preserve (EIR 94-005) prepared for the original approval of the subject project (PLN080350); and
- 2) Approve PLN130509, based on the findings and evidence and subject to the conditions of approval (**Exhibit A**)

PROJECT OVERVIEW:

On August 26, 2009, the Planning Commission considered an Addendum to the Environmental Impact Report for the Santa Lucia Preserve (EIR 94-005) and approved a Combined Development Permit (PLN080350) consisting of: 1) Administrative Permit and Design Approval to allow the construction of a 6,230 square foot two-story single family dwelling with an attached 1,000 square-foot three-car garage, a 1,055 square-foot barn, an 800 square foot swimming pool, 15 garden walls totaling 580 linear feet; 2) Use Permit to allow the removal of 11 oak trees and the re-location of 5 oak trees; and 3) Administrative Permit to allow the construction of an 840 square-foot detached senior citizen unit with a 253 square-foot covered terrace and grading consisting of 240 cubic yards of cut and 75 cubic yards of fill. This discretionary permit was approved subject to 29 conditions of approval.

As part of the review of the extension request, County Agencies deleted some conditions of approval and added others to reflect current standards. On May 24, 2011, the Monterey County Board of Supervisors adopted Ordinance No. 5177 repealing regulations for senior citizen units and replacing these with accessory dwelling unit regulations (Section 21.64.030, Title 21 of the Monterey County Zoning Ordinance). Under the revised regulations, an accessory dwelling is allowed, with an Administrative Permit, as an appropriate means of providing affordable housing for caretakers, convalescent help, domestic employees, and other similar uses. Staff has modified

the project description accordingly and removed the condition requiring a deed restriction for a senior citizens unit consistent with the accessory dwelling regulations in the Zoning Ordinance.

The resolution approved by the Planning Commission on August 26, 2009 (Resolution No. 09040) states in the project description that 11 Oak trees are to be removed and 5 oak trees will be relocated. Consistency Finding C of project resolution states that 28 trees will be removed. The resolution for this extension has been corrected to reflect the correct total number of trees being removed within the project description.

Staff has reviewed the extension request in relation to the 2010 General Plan, Carmel Valley Master Plan, and Monterey County Zoning Ordinance (Title 21) and has found that the overall project is consistent with the current regulations. Staff supports the extension request as the circumstances of the project approval have not changed. All remaining conditions of approval contained in Planning Commission Resolution No. 09040 have been carried forward with this extension.

OTHER AGENCY INVOLVEMENT: The following agencies and departments reviewed this project:

- √ RMA - Public Works Department
- √ RMA - Planning
- √ Environmental Health Bureau
- √ Water Resources Agency
- √ Monterey County Regional Fire Protection District

Agencies that submitted comments are noted with a check mark ("√"). Conditions recommended by RMA – Public Works, Environmental Health Bureau, Water Resources, Monterey County Regional Fire Protection District, and RMA - Planning have been incorporated into the Condition Compliance/Mitigation Monitoring and Reporting Plan attached to the draft resolution (**Exhibit A**).

The project was not referred to the Carmel Valley Land Use Advisory Committee (LUAC) for review. Based on the LUAC Procedure guidelines adopted by the Monterey County Board of Supervisors per Resolution No. 08-338, this application did not warrant referral to the LUAC because the project did not require an Initial Study or Environmental Impact Report.

Note: The decision on this project is appealable to the Board of Supervisors



Maria Lopez, Land Use Technician
(831) 755-5239, lopezm@co.monterey.ca.us

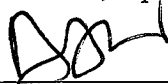

Dan Lister, Assistant Planner
(831) 759-6617, listerdm@co.monterey.ca.us
September 23, 2013

cc: Front Counter Copy; Planning Commission; Monterey County Regional Fire Protection District; RMA-Public Works Department; Environmental Health Bureau; Water Resources Agency; Wanda Hickman, Planning Services Manager; Dan Lister, Project Planner; Attorneys Benefits Corporation, Owner; Paul and Nancy Sallaberry, Representative; The Open Monterey Project; LandWatch; Planning File PLN130509

Attachments: Exhibit A Draft Resolution, including:
• Conditions of Approval
• Site Plan, Floor Plan and Elevations
Exhibit B Letter of Extension Request
Exhibit C Resolution No. 09040
Exhibit D Technical Addendum
Exhibit E Vicinity Map

This report was reviewed by Luis Osorio, Senior Planner

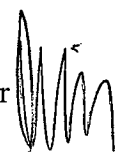

**EXHIBIT A
DRAFT RESOLUTION**

**Before the Planning Commission in and for the
County of Monterey, State of California**

In the matter of the application of:

Attorney's Benefit Corporation (PLN130509)

RESOLUTION NO. _____

Resolution by the Monterey County Planning
Commission:

- 1) Considering a Technical Addendum to a previously certified EIR for the Santa Lucia Preserve Comprehensive Development Plan (EIR No. 94-005) prepared for the original approval of the Combined Development Permit (PLN080350) and determining that the Addendum is still adequate and is the appropriate environmental document for the extension request; and
- 2) Approving a three-year extension of Combined Development Permit No. PLN080350 consisting of: a) Administrative Permit to allow the construction of a 6,230 square foot two-story single family dwelling with an attached 1,000 square-foot three-car garage, a 1,055 square-foot barn, an 800 square foot swimming pool, 15 garden walls totaling 580 linear feet in the "S" (Site Plan Review) zoning district; b) Administrative Permit to allow an 840 square foot detached accessory dwelling unit with a 253 square-foot covered terrace; and c) Use Permit to allow the removal of 28 oak trees (5 of the oak trees to be re-located on-site); and grading consisting of 240 cubic yards of cut and 75 cubic yards of fill; and d) a Design Approval.

[PLN130509, Attorneys Benefits Corporation,
8 Goodrich Trail, Carmel, Carmel Valley Master Plan,
(Assessor's Parcel Number: 239-102-021-000)]

The Attorneys Benefits Corporation application (PLN130509) came on for public hearing before the Monterey County Planning Commission on October 9, 2013. Having considered all the written and documentary evidence, the administrative record, the staff report, oral testimony, and other evidence presented, the Planning Commission finds and decides as follows:

FINDINGS

1. **FINDING:** The Monterey County has received and processed a Permit Extension to PLN080350.
- EVIDENCE:**
- a) An application for a three-year permit extension was submitted on July 9, 2013. The original Planning Permit was approved on August 26, 2009 and was set to expire on August 26, 2013. Condition of approval No. 4 incorrectly stated August 12, 2013 as the expiration date. Therefore, staff has used August 26, 2013 as the expiration date and process the extension request pursuant to Section 21.76.110.A (Extension of Combined Development Permits).
 - b) The property is located at 8 Goodrich Trail, Carmel, Carmel Valley Master Plan (Assessor's Parcel Number: 239-102-021-000).
 - c) On August 26, 2009, the Planning Commission approved the project under PLN080350 and adopted the Addendum to the Environmental Impact Report for the Santa Lucia Preserve (EIR 94-005). The approved project includes: 1) Administrative Permit and Design Approval to allow the construction of a 6,230 square foot two-story single family dwelling with an attached 1,000 square foot three-car garage, a 1,055 square foot barn, an 800 square foot swimming pool, 15 garden walls totaling 580 linear feet; 2) Use Permit to allow the removal of 11 oak trees and the re-location of 5 oak trees; and 3) Administrative Permit to allow the construction of an 840 square foot detached senior citizen unit with a 253 square foot covered terrace and grading consisting of 240 cubic yards of cut and 75 cubic yards of fill.
 - d) Accessory Dwelling Unit: The previously approved project included an Administrative Permit for an 840 square foot detached senior citizen unit with a 253 square foot covered terrace. On May 24, 2011, the Monterey County Board of Supervisors adopted Ordinance No. 5177 repealing regulations for senior citizen units and replacing these with accessory dwelling unit regulations. In compliance with State Law (AB1866 – Second Unit Law), under the revised regulations, an accessory dwelling is allowed, with an Administrative Permit, as an appropriate means of providing affordable housing for caretakers, convalescent help, domestic employees, and other similar uses. Staff has modified the project description accordingly and removed the condition requiring a deed restriction for a senior citizens unit consistent with the accessory dwelling regulation in the Zoning Ordinance.
 - e) Pursuant to Section 21.76.110.A (Extension of Combined Development Permits) “The appropriate authority may extend a Combined Development Permit upon receipt of a written request from the permittee, provided such request is made at least thirty (30) days to the expiration of the Combined Development Permit. The written request shall be filed with the Appropriate authority and set forth reasons supporting the request.” On July 9, 2013, the applicant, Paul & Nancy Sallaberry submitted a letter requesting an extension to Planning Permit PLN080350 consistent with the provisions of Chapter 21.76.
 - f) As part of the review of County Agencies some conditions of approval were deleted and others were added. The modified conditions are: The RMA – Planning has the deleted original Condition No. 11 and added original Condition Nos. 1, 3, 5, 7, and 9; The Monterey County Regional Fire District has deleted original Condition No. 29 and added

Condition Nos. 33 and 34; The Water Resources Agency has deleted original Condition No. 21 and added Condition No. 26; and The Public Works Department and Environmental Health Bureau have not proposed changes to the original conditions of approval. The original conditions of approval are still applicable to this extension permit. New conditions of approval have been incorporated as part of this extension.

- g) The application, project plans, and related support materials submitted by the project applicant to the Monterey County Resource Management Agency – Planning for the proposed permit extension found in Project Files PLN080350 and PLN130509.

2. **FINDING:**

The permit extension includes no changed circumstances from the previously approved permit. As approved, permit number PLN130509 will become and be referred to as the approved permit.

EVIDENCE:

- a) The project does not include changes in circumstances from the previously approved permit (PLN080350).
- b) Pursuant to Section 21.76.110 (Extension of Combined Development Permits), the Appropriate Authority may extend a Combined Development Permit subject to the provision of Chapter 21.78.040.A (Public Hearings); the structures as proposed have no changes in circumstances including: site development standards, grading quantities, square footage, site coverage, and colors and materials.
- c) The application, project plans, and related support materials submitted by the project applicant to the Monterey County Resource Management Agency – Planning Department for the proposed extension found in Project Files PLN080350 and PLN130509.

3. **FINDING:**

An Addendum to the certified EIR for the Santa Lucia Preserve (attached to the August 26, 2009 staff report to the Planning Commission) was prepared pursuant to Code of Regulations, Title 14, Section 15164. The Addendum reflects the County's independent judgment and analysis. The Addendum is still adequate for the extension request.

EVIDENCE:

- a) The Addendum did not identify any significant change in circumstances in the vicinity of the project that would have resulted in significant changes to the environmental impacts identified in the certified EIR or that would have required changes to the approved mitigation measures or new mitigation measures.
- b) The Addendum to the certified EIR discussed minor technical changes or additions to the certified EIR and is an appropriate document under CEQA for the approval of this request for a project extension. None of the conditions described in CEQA Guidelines Section 15162 calling for preparation of a subsequent EIR have occurred since the original approval of the project. Monterey County, as the CEQA Lead Agency, has determined that no Subsequent or Supplemental EIR is required pursuant to Public Resources Code Section 21166 or CEQA Guidelines Sections 15162, 15163, or 15164, as none of the conditions described in those sections have occurred. The Addendum is still adequate and the appropriate document for the extension request.
- c) County staff prepared the Addendum (Exhibit E).

- d) Administrative record contained in the project file.
4. **FINDING:** The project as approved is appealable to the Board of Supervisors.
EVIDENCE: a) Section 21.80.040.D of the Monterey County Zoning Ordinance states that the proposed project is appealable to the Board of Supervisors

DECISION

NOW, THEREFORE, based on the above findings and evidence, the Planning Commission does hereby:

1. Determines that the Technical Addendum to a previously certified EIR for the Santa Lucia Preserve Comprehensive Development Plan (EIR No. 94-005) prepared for the original approval of the Combined Development Permit (PLN080350) is still adequate and is the appropriate environmental document for the extension request; and
2. Approves a three-year extension of Combined Development Permit No. PLN080350 consisting of: a) Administrative Permit and Design Approval to allow the construction of a 6,230 square foot two-story single family dwelling with an attached 1,000 square-foot three-car garage, an 840 square-foot detached senior citizen unit with a 253 square-foot covered terrace, a 1,055 square-foot barn, an 800 square foot swimming pool, 15 garden walls totaling 580 linear feet; b) Use Permit to allow the removal of 11 oak trees and the re-location of 5 oak trees; and grading consisting of 240 cubic yards of cut and 75 cubic yards of fill, in general conformance with the attached plans and subject to the attached conditions, all being attached hereto and incorporated herein by reference;

PASSED AND ADOPTED this 9th day of October, 2013 upon motion of _____, seconded by _____, by the following vote:

AYES:
NOES:
ABSENT:
ABSTAIN:

Mike Novo, Secretary

COPY OF THIS DECISION MAILED TO APPLICANT ON _____.

THIS APPLICATION IS APPEALABLE TO THE BOARD OF SUPERVISORS.

IF ANYONE WISHES TO APPEAL THIS DECISION, AN APPEAL FORM MUST BE COMPLETED AND SUBMITTED TO THE CLERK TO THE BOARD ALONG WITH THE APPROPRIATE FILING FEE ON OR BEFORE _____.

This decision, if this is the final administrative decision, is subject to judicial review pursuant to California Code of Civil Procedure Sections 1094.5 and 1094.6. Any Petition for Writ of Mandate must be filed with the Court no later than the 90th day following the date on which this decision becomes final.

NOTES

1. You will need a building permit and must comply with the Monterey County Building Ordinance in every respect.

Additionally, the Zoning Ordinance provides that no building permit shall be issued, nor any use conducted, otherwise than in accordance with the conditions and terms of the permit granted or

until ten days after the mailing of notice of the granting of the permit by the appropriate authority, or after granting of the permit by the Board of Supervisors in the event of appeal.

Do not start any construction or occupy any building until you have obtained the necessary permits and use clearances from the Monterey County Planning Department and Building Services Department office in Salinas.

2. This permit expires 3 years after the above date of granting thereof unless construction or use is started within this period.

Monterey County Planning Department

DRAFT Condition of Approval Implementation Plan/Mitigation Monitoring Reporting Plan

PLN130509

1. PD001 - SPECIFIC USES ONLY

Responsible Department: Planning Department

Condition/Mitigation Monitoring Measure: This permit (PLN130509) allows a three-year extension of Combined Development Permit No. PLN080350 consisting of: a) Administrative Permit to allow the construction of a 6,230 square foot two-story single family dwelling with an attached 1,000 square-foot three-car garage, a 1,055 square-foot barn, an 800 square foot swimming pool, 15 garden walls totaling 580 linear feet in the "S" (Site Plan Review) zoning district; b) Administrative Permit to allow an 840 square foot detached accessory dwelling unit with a 253 square-foot covered terrace; and c) Use Permit to allow the removal of 28 oak trees (5 of the oak trees to be re-located on-site); and grading consisting of 240 cubic yards of cut and 75 cubic yards of fill; and d) a Design Approval. The property is located at 8 Goodrich Trail, Carmel (Assessor's Parcel Number 239-102-021-000), Carmel Valley Master Plan. This permit was approved in accordance with County ordinances and land use regulations subject to the terms and conditions described in the project file. Neither the uses nor the construction allowed by this permit shall commence unless and until all of the conditions of this permit are met to the satisfaction of the Director of RMA - Planning. Any use or construction not in substantial conformance with the terms and conditions of this permit is a violation of County regulations and may result in modification or revocation of this permit and subsequent legal action. No use or construction other than that specified by this permit is allowed unless additional permits are approved by the appropriate authorities. To the extent that the County has delegated any condition compliance or mitigation monitoring to the Monterey County Water Resources Agency, the Water Resources Agency shall provide all information requested by the County and the County shall bear ultimate responsibility to ensure that conditions and mitigation measures are properly fulfilled. (RMA - Planning)

Compliance or Monitoring Action to be Performed: The Owner/Applicant shall adhere to conditions and uses specified in the permit on an ongoing basis unless otherwise stated.

2. PD002 - NOTICE PERMIT APPROVAL

Responsible Department: Planning Department

Condition/Mitigation Monitoring Measure: The applicant shall record a Permit Approval Notice. This notice shall state:
"A Permit (Resolution Number ***) was approved by the Planning Commission for Assessor's Parcel Number: 239-102-021-000 on October 9, 2013. The permit was granted subject to 30 conditions of approval which run with the land. A copy of the permit is on file with Monterey County RMA - Planning."

Proof of recordation of this notice shall be furnished to the Director of RMA - Planning prior to issuance of building permits or commencement of the use. (RMA - Planning)

Compliance or Monitoring Action to be Performed: Prior to the issuance of grading and building permits or commencement of use, the Owner/Applicant shall provide proof of recordation of this notice to the RMA - Planning.

3. PD002(A) - ATTACH RESOLUTION TO CONSTRUCTION PLANS

Responsible Department: Planning Department

Condition/Mitigation Monitoring Measure: A copy of the Resolution of Approval (Resolution No. ***) for the three-year Extension Permit (Planning File No.: PLN130509) shall be incorporated onto the construction plans for the project prior to the issuance of a grading or building permit. The Contractor/Owner/Applicant shall be responsible for compliance with all conditions of approval. (RMA - Planning)

Compliance or Monitoring Action to be Performed: Prior to commencement of any grading or construction activities, the Owner/Applicant shall submit evidence to RMA-Planning for review and approval, that the Resolution of Approval, for the project, has been incorporated onto the construction plans for the project/approved development.

Ongoing throughout construction and until all Conditions of Approval and/or Mitigation Measures have been complied with, the Contractor/Owner/Applicant shall provide evidence of compliance with Conditions of Approval to the Responsible Land Use Department as specified in the "Condition of Approval Implementation Plan/Mitigation Monitoring Reporting Plan."

4. PD003(A) - CULTURAL RESOURCES NEGATIVE ARCHAEOLOGICAL REPORT

Responsible Department: Planning Department

Condition/Mitigation Monitoring Measure: If, during the course of construction, cultural, archaeological, historical or paleontological resources are uncovered at the site (surface or subsurface resources) work shall be halted immediately within 50 meters (165 feet) of the find until a qualified professional archaeologist can evaluate it. Monterey County RMA - Planning and a qualified archaeologist (i.e., an archaeologist registered with the Register of Professional Archaeologists) shall be immediately contacted by the responsible individual present on-site. When contacted, the project planner and the archaeologist shall immediately visit the site to determine the extent of the resources and to develop proper mitigation measures required for recovery. (RMA - Planning)

-- (Condition No. 3, PLN080350) --

Compliance or Monitoring Action to be Performed: The Owner/Applicant shall adhere to this condition on an on-going basis.

Prior to the issuance of grading or building permits and/or prior to the recordation of the final/parcel map, whichever occurs first, the Owner/Applicant shall include requirements of this condition as a note on all grading and building plans. The note shall state "Stop work within 50 meters (165 feet) of uncovered resource and contact Monterey County RMA - Planning and a qualified archaeologist immediately if cultural, archaeological, historical or paleontological resources are uncovered." When contacted, the project planner and the archaeologist shall immediately visit the site to determine the extent of the resources and to develop proper mitigation measures required for the discovery.

5. PD032(A) - PERMIT EXPIRATION

Responsible Department: Planning Department

Condition/Mitigation Monitoring Measure: The permit shall be granted for a time period of three years, to expire on October 9, 2016 unless use of the property or actual construction has begun within this period. (RMA-Planning)

Compliance or Monitoring Action to be Performed: Prior to the expiration date stated in the condition, the Owner/Applicant shall obtain a valid grading or building permit and/or commence the authorized use to the satisfaction of the RMA-Director of Planning. Any request for extension must be received by RMA-Planning at least 30 days prior to the expiration date.

6. PD004 - INDEMNIFICATION AGREEMENT

Responsible Department: Planning Department

Condition/Mitigation Monitoring Measure: The property owner agrees as a condition and in consideration of approval of this discretionary development permit that it will, pursuant to agreement and/or statutory provisions as applicable, including but not limited to Government Code Section 66474.9, defend, indemnify and hold harmless the County of Monterey or its agents, officers and employees from any claim, action or proceeding against the County or its agents, officers or employees to attack, set aside, void or annul this approval, which action is brought within the time period provided for under law, including but not limited to, Government Code Section 66499.37, as applicable. The property owner will reimburse the County for any court costs and attorney's fees which the County may be required by a court to pay as a result of such action. The County may, at its sole discretion, participate in the defense of such action; but such participation shall not relieve applicant of his/her/its obligations under this condition. An agreement to this effect shall be recorded upon demand of County Counsel or concurrent with the issuance of building permits, use of property, filing of the final map, recordation of the certificates of compliance whichever occurs first and as applicable. The County shall promptly notify the property owner of any such claim, action or proceeding and the County shall cooperate fully in the defense thereof. If the County fails to promptly notify the property owner of any such claim, action or proceeding or fails to cooperate fully in the defense thereof, the property owner shall not thereafter be responsible to defend, indemnify or hold the County harmless. (RMA - Planning)

Compliance or Monitoring Action to be Performed: Upon demand of County Counsel or concurrent with the issuance of building permits, use of the property, recording of the final/parcel map, whichever occurs first and as applicable, the Owner/Applicant shall submit a signed and notarized Indemnification Agreement to the Director of RMA-Planning for review and signature by the County.

Proof of recordation of the Indemnification Agreement, as outlined, shall be submitted to RMA-Planning .

7. PD007- GRADING WINTER RESTRICTION

Responsible Department: Planning Department

Condition/Mitigation Monitoring Measure: No land clearing or grading shall occur on the subject parcel between October 15 and April 15 unless authorized by the Director of RMA - Building Services. (RMA - Planning and RMA - Building Services)

-- (Condition No. 6, PLN080350) --

Compliance or Monitoring Action to be Performed: The Owner/Applicant, on an on-going basis, shall obtain authorization from the Director of RMA - Building Services Department to conduct land clearing or grading between October 15 and April 15.

8. PD009 - GEOTECHNICAL CERTIFICATION

Responsible Department: Planning Department

Condition/Mitigation Monitoring Measure: Prior to final inspection, the geotechnical consultant shall provide certification that all development has been constructed in accordance with the geotechnical report. (RMA - Planning and RMA - Building Services)

-- (Condition No. 7, PLN080350) --

Compliance or Monitoring Action to be Performed: Prior to final inspection, the Owner/Applicant/Geotechnical Consultant shall submit certification by the geotechnical consultant to RMA-Building Services showing project's compliance with the geotechnical report.

9. PDSP001 - LANDSCAPE PLAN AND MAINTENANCE - SANTA LUCIA PRESERVE (NON-STANDARD)

Responsible Department: Planning Department

Condition/Mitigation Monitoring Measure: The site shall be landscaped. At least three (3) weeks prior to occupancy, three (3) copies of a landscaping plan shall be submitted to the Director of the RMA - Planning Department. A landscape plan review fee is required for this project. Fees shall be paid at the time of landscape plan submittal.

Before occupancy, landscaping shall be either installed or a certificate of deposit or other form of surety made payable to Monterey County RMA - Planning Department.

The landscaping plan shall be in sufficient detail to identify the location, species, and size of the proposed landscaping materials and shall include an irrigation plan. The plan shall be accompanied by a nursery or contractor's estimate of the cost of installation of the plan and shall implement the following:

1. Spread of Invasive Species: Implement the provisions of the Resource Management Plan for the San Carlos Ranch (1994) which specify that non-native species known to be invasive shall not be used in landscaping, that invasive exotics shall be controlled by revegetation of disturbed areas with native plants, that the use of landscape species known to be invasive shall be prohibited, and that species such as French broom and pampas grass shall be actively eradicated.

2. Landscape Irrigation: Selection of landscape species shall emphasize species not requiring irrigation such as drought-tolerant native species from local sources, or drought-tolerant non-native that are known to be non-invasive. If irrigation systems are installed, they shall be designed to minimize runoff of irrigation water into adjacent areas of native vegetation.

3. Fertilizer and Pesticide Application: In the design of landscaping, emphasis shall be placed on the use of species not requiring herbicides, pesticides, or fertilizers.

-- (Condition No. 8, PLN080350) --

Compliance or Monitoring Action to be Performed: Prior to Occupancy the owner, applicant, licensed landscape contractor, licensed landscape architect; Landscaping shall be either installed or a certificate of deposit or other form of surety made payable to Monterey County for that cost estimate shall be submitted to the Monterey County RMA - Planning Department.

Ongoing the owner/applicant; All landscaped areas and fences shall be continuously maintained by the applicant; all plant material shall be continuously maintained in a litter-free, weed-free, healthy, growing condition.

10. PD014(A) - LIGHTING - EXTERIOR LIGHTING PLAN

Responsible Department: Planning Department

Condition/Mitigation Monitoring Measure: All exterior lighting shall be unobtrusive, down-lit, harmonious with the local area, and constructed or located so that only the intended area is illuminated and off-site glare is fully controlled. The applicant shall submit three (3) copies of an exterior lighting plan which shall indicate the location, type, and wattage of all light fixtures and include catalog sheets for each fixture. The lighting shall comply with the requirements of the California Energy Code set forth in California Code of Regulations Title 24 Part 6. The exterior lighting plan shall be subject to approval by the Director of RMA - Planning, prior to the issuance of building permits. (RMA - Planning)

-- (Condition No. 9, PLN080350) --

Compliance or Monitoring Action to be Performed: Prior to the issuance of building permits, the Owner/Applicant shall submit three copies of the lighting plans to RMA - Planning for review and approval. Approved lighting plans shall be incorporated into final building plans.

Prior to occupancy and on an on-going basis, the Owner/Applicant shall ensure that the lighting is installed and maintained in accordance with the approved plan.

11. PD016 - NOTICE OF REPORT

Responsible Department: Planning Department

Condition/Mitigation Monitoring Measure: Prior to issuance of building or grading permits, a notice shall be recorded with the Monterey County Recorder which states:

"The following reports have been prepared for the project:

- "Construction Impacts Analysis" (LIB090351) was prepared by Maureen Hamb-WCISA Certified Arborist No. 2280, Santa Cruz, California, October 1, 2008.
- "Subsequent Construction Impact Analysis" (LIB090350) was prepared by Maureen Hamb-WCISA Certified Arborist No. 2280, Santa Cruz, California, March 9, 2009.
- "Geotechnical Engineering Investigation" (LIB090352) was prepared by Moore Twining Associates, Inc., Fresno, California, July 11, 2008.

All development shall be in accordance with this report."
(RMA - Planning)

-- (Condition No. 10, PLN080350) --

Compliance or Monitoring Action to be Performed: Prior to the issuance of grading and building permits, the Owner/Applicant shall submit proof of recordation of this notice to RMA - Planning.

Prior to occupancy, the Owner/Applicant shall submit proof, for review and approval, that all development has been implemented in accordance with the report to the RMA - Planning.

12. PD041 - HEIGHT VERIFICATION

Responsible Department: Planning Department

Condition/Mitigation Monitoring Measure: The applicant shall have a benchmark placed upon the property and identify the benchmark on the building plans. The benchmark shall remain visible on-site until final building inspection. The applicant shall provide evidence from a licensed civil engineer or surveyor to the Director of RMA - Building Services for review and approval, that the height of the structure(s) from the benchmark is consistent with what was approved on the building permit associated with this project. (RMA - Planning and RMA - Building Services)

-- (Condition No. 12, PLN080350) --

Compliance or Monitoring Action to be Performed: Prior to the issuance of grading or building permits, the Owner/Applicant shall have a benchmark placed upon the property and identify the benchmark on the building plans. The benchmark shall remain visible onsite until final building inspection.

Prior to the foundation pre-pour inspection, the Owner/Applicant shall provide evidence from a licensed civil engineer or surveyor, to the Director of RMA- Building Services for review and approval, that the height of first finished floor from the benchmark is consistent with what was approved on the building permit.

Prior to the final inspection, the Owner/Applicant/Engineer shall provide evidence from a licensed civil engineer or surveyor, to the Director of RMA- Building Services for review and approval, that the height of the structure(s) from the benchmark is consistent with what was approved on the building permit.

13. PDSP002 - TREE AND ROOT PROTECTION - SANTA LUCIA PRESERVE (NON-STANDARD)

Responsible Department: Planning Department

Condition/Mitigation Monitoring Measure: Tree and root protection shall include the implementation of the "Rancho San Carlos Forest Management Plan prepared by Ralph Osterling Consultants, Inc., San Mateo, February 18, 1984 and the "Construction Impact Analysis" prepared for this parcel by Maureen Hamb-WCISA Certified Arborist No. 2280 dated October 1, 2008 (Library no. LIB090351). Trees which are located close to the construction site shall be protected from inadvertent damage from construction equipment by fencing off the canopy driplines and/or critical root zones (whichever is greater) with protective materials, wrapping trunks with protective materials, avoiding fill of any type against the base of the trunks and avoiding an increase in soil depth at the feeding zone or drip-line of the retained trees. Said protection, approved by the project certified arborist, shall be demonstrated prior to issuance of building permits subject to the approval of the RMA - Director of Planning. If there is any potential for damage, all work must stop in the area and a report, with mitigation measures, shall be submitted by the certified arborist. Should any additional trees not included in this report be harmed, during grading or construction activities, in such a way where removal is required, the owner/applicant shall obtain required permits. (Santa Lucia Preserve EIR MM32) (RMA - Planning Department).

-- (Condition No. 14, PLN080350) --

Compliance or Monitoring Action to be Performed: Prior to the issuance of grading or building permits the owner/applicant shall submit evidence of tree protection to the RMA - Planning Department for review and approval.

During construction the owner/applicant shall submit on-going evidence that tree protection measures are in place through out grading and construction phases. If damage is possible, submit an interim report prepared by a certified arborist.

Prior to final inspection the owner/applicant shall submit photographs of the trees on the property to the RMA - Planning Department after construction to document that the tree protection has been successful or if follow-up remediation or additional permits are required.

14. PD035 - UTILITIES UNDERGROUND

Responsible Department: Planning Department

Condition/Mitigation Monitoring Measure: All new utility and distribution lines shall be placed underground. (RMA - Planning and RMA-Public Works)

-- (Condition No. 15, PLN080350) --

Compliance or Monitoring Action to be Performed: On an on-going basis, the Owner/Applicant shall install and maintain utility and distribution lines underground.

15. PDSP003 - TREE REPLACEMENT - SANTA LUCIA PRESERVE (NON-STANDARD)

Responsible Department: Planning Department

Condition/Mitigation Monitoring Measure: The applicant shall plant 77 coast live oak trees. All non-landmark oak trees removed as a result of the project (19 trees) shall be replaced at a 3:1 ratio and all landmark trees (4 trees) at a 5:1 ratio. All oak trees removed shall be replaced in on-site areas suitable for supporting oak species as determined by a qualified resource ecologist. The minimum replacement size shall be 5 gallons. Nursery and/or field propagation of oak seedlings and/or saplings shall be initiated prior to the onset of the particular development phase that results in the loss of oak trees. The reforestation program shall include a monitoring element that guarantees a success period of not less than 5 years after planting and a success ration threshold of no less than 90%. At five years, a report shall be prepared by a registered forester or arborist and submitted to the Planning Department for review and approval of the Director of Planning describing reforestation activities conducted during the year and shall describe success rates and corrective measures provided to adjust program based on earlier successes or failures. This condition shall cease once the requirement number of replacement trees for a particular phase have passed the five-year anniversary completion date required for plan success. The property owner must enter into a contractual agreement with a certified arborist from Monterey County's list of approved arborist consultants. The agreement must require monitoring by an arborist (from the County's list of approved arborist consultants) to ensure a success period of the referenced replacement trees for a minimum of 5 years. (Santa Lucia Preserve EIR MM27 and 36) (RMA - Planning Department)

-- (Condition No. 16, PLN080350) --

Compliance or Monitoring Action to be Performed: Prior to final inspection the owner/applicant shall submit photographic evidence to the Director of the RMA - Planning Department demonstrating that required replacement trees have been planted.

5 years after successful tree planting the owner/applicant shall provide evidence after 5 years that the tree planting has been successful.

For a minimum of 5 years the owner must enter into a contractual agreement with a certified arborist from Monterey County's list of approved arborist consultants. The agreement must require monitoring by an arborist (from the County's list of approved consultants) to ensure a success period of the referenced replacement trees for a minimum of 5 years.

16. PW0043 - REGIONAL DEVELOPMENT IMPACT FEE

Responsible Department: Public Works Department

Condition/Mitigation Monitoring Measure: Prior to issuance of building permits, applicant shall pay the Regional Development Impact Fee (RDIF) pursuant to Monterey Code Chapter 12.90. The fee amount shall be determined based on the parameters adopted in the current fee schedule.

-- (Condition No. 17, PLN080350) --

Compliance or Monitoring Action to be Performed: Prior to issuance of Building Permits Owner/Applicant shall pay Monterey County Building Services Department the traffic mitigation fee. Owner/Applicant shall submit proof of payment to the DPW.

17. PW0006 - CARMEL VALLEY

Responsible Department: Public Works Department

Condition/Mitigation Monitoring Measure: The Applicant shall pay the Carmel Valley Master Plan Area Traffic Mitigation fee pursuant to the Board of Supervisors Resolution NO. 95-140, adopted September 12, 1995 (Fees are updated annually based on CCI).

-- (Condition No. 18, PLN080350) --

Compliance or Monitoring Action to be Performed: Prior to Building Permits Issuance Owner/Applicant shall pay to PBI the required traffic mitigation fee.

18. PW0040 - HIGHWAY 1 SHORT TERM IMPROVEMENTS

Responsible Department: Public Works Department

Condition/Mitigation Monitoring Measure: Applicant shall Contribute \$833 (2013 Dollars) to County of Monterey as payment of the project's prorata share at the cost of short-term operational improvements to State Highway One.

-- (Condition No. 19, PLN080350) --

Compliance or Monitoring Action to be Performed: Prior to Issuance of Building Permits Owner/Applicant shall pay to PBI required Traffic Mitigation Fee.

19. EH11-SEPTIC SYSTEM DESIGN

Responsible Department: Health Department

Condition/Mitigation Monitoring Measure: SUBMIT PLANS FOR REVIEW AND APPROVAL SHOWING THE LOCATION AND DESIGN OF THE PROPOSED SEPTIC SYSTEM MEETING THE STANDARDS FOUND IN CHAPTER 15.20 OF THE MONTEREY COUNTY CODE (SEPTIC ORDINANCE) AND "PROHIBITIONS" CENTRAL COAST BASIN PLAN, RWQCB.

-- (Condition No. 20, PLN080350) --

Compliance or Monitoring Action to be Performed: PRIOR TO FILLING THE FINAL PARCEL MAP OR ISSUANCE OF BUILDING PERMIT. DIVISION OF ENVIRONMENTAL HEALTH MUST APPROVE PLANS. APPLICANT SHALL OBTAIN A PERMIT TO INSTALL THE SEPTIC SYSTEM.

20. WRSP1 - DRAINAGE PLAN

Responsible Department: Water Resources Agency

Condition/Mitigation Monitoring Measure: The applicant shall provide a drainage plan, prepared by a registered civil engineer or licensed architect, to mitigate on-site and off-site impacts. Impervious surface stormwater runoff shall be directed to the existing detention ponds for the Santa Lucia Preserve Subdivision. Drainage improvements shall be constructed in accordance with plans approved by the Water Resources Agency. (Water Resources Agency)

-- (Revised condition replacing Condition No. 22, PLN080350) --

Compliance or Monitoring Action to be Performed: Prior to issuance of any construction permit, the owner/applicant shall submit a drainage plan with the construction permit application.

The Building Services Department will route a plan set to the Water Resources Agency for review and approval.

21. WR049 - WATER AVAILABILITY CERTIFICATION

Responsible Department: Water Resources Agency

Condition/Mitigation Monitoring Measure: The applicant shall provide the Monterey County Water Resources Agency proof of water availability in the form of a complete Monterey Peninsula Water Management District Water Release Form. (Water Resources Agency)

Compliance or Monitoring Action to be Performed: Prior to issuance of any construction permit, the owner/applicant shall submit a Water Release Form to the Water Resources Agency for review and approval.

A copy of the Water Release Form can be obtained at the Monterey Peninsula Water Management District, the Water Resources Agency, or online at:
www.mcwra.co.monterey.ca.us.

22. WR40 - WATER CONSERVATION MEASURES

Responsible Department: Water Resources Agency

Condition/Mitigation Monitoring Measure: The applicant shall comply with Ordinance No. 3932, or as subsequently amended, of the Monterey County Water Resources Agency pertaining to mandatory water conservation regulations. The regulations for new construction require, but are not limited to:

- a. All toilets shall be ultra-low flush toilets with a maximum tank size or flush capacity of 1.6 gallons, all shower heads shall have a maximum flow capacity of 2.5 gallons per minute, and all hot water faucets that have more than ten feet of pipe between the faucet and the hot water heater serving such faucet shall be equipped with a hot water recirculating system.
- b. Landscape plans shall apply xeriscape principles, including such techniques and materials as native or low water use plants and low precipitation sprinkler heads, bubblers, drip irrigation systems and timing devices. (Water Resources Agency)

-- (Condition No. 21. PLN080350) --

Compliance or Monitoring Action to be Performed: Prior to final building inspection.occupancy, compliance shall verified by building inspector at final inspection.

23. FIRE007 - DRIVEWAYS

Responsible Department: Fire

Condition/Mitigation Monitoring Measure: Driveways shall not be less than 12 feet wide unobstructed, with an unobstructed vertical clearance of not less than 15 feet. The grade for all driveways shall not exceed 15 percent. Where the grade exceeds 8 percent, a minimum structural roadway surface of 0.17 feet of asphaltic concrete on 0.34 feet of aggregate base shall be required. The driveway surface shall be capable of supporting the imposed load of fire apparatus (22 tons), and be accessible by conventional-drive vehicles, including sedans. For driveways with turns 90 degrees and less, the minimum horizontal inside radius of curvature shall be 25 feet. For driveways with turns greater than 90 degrees, the minimum horizontal inside radius curvature shall be 28 feet. For all driveway turns, an additional surface of 4 feet shall be added. All driveways exceeding 150 feet in length, but less than 800 feet in length, shall provide a turnout near the midpoint of the driveway. Where the driveway exceeds 800 feet, turnouts shall be provided at no greater than 400-foot intervals. Turnouts shall be a minimum of 12 feet wide and 30 feet long with a minimum of 25-foot taper at both ends. Turnarounds shall be required on driveways in excess of 150 feet of surface length and shall be located within 50 feet of the primary building. The minimum turning radius for a turnaround shall be 40 feet from the center line of the driveway. If a hammerhead/T is used, the top of the "T" shall be a minimum of 60 feet in length. Monterey County Regional Fire Protection District

-- (Condition No. 23, PLN080350) --

Compliance or Monitoring Action to be Performed: Prior to issuance of grading and/or building permits, the Applicant shall incorporate the specification of the driveway into design and print the text of this condition as "Fire Department Notes" on plans.

Prior to requesting a final building inspection, the Applicant shall complete the installation of driveway improvements and obtain fire department approval the final fire inspection.

24. FIRE008 - GATES

Responsible Department: Fire

Condition/Mitigation Monitoring Measure: All gates providing access from a road to a driveway shall be located at least 30 feet from the roadway and shall open to allow a vehicle to stop without obstructing traffic on the road. Gate entrances shall be at least the width of the traffic lane but in no case less than 12 feet wide. Where a one-way road with a single traffic lane provides access to a gated entrance, a 40-foot turning radius shall be used. Where gates are to be locked, the installation of a key box or other acceptable means for immediate access by emergency equipment may be required. Monterey County Regional Fire Protection District

-- (Condition No. 24, PLN080350) --

Compliance or Monitoring Action to be Performed: Prior to issuance of grading and/or building permits, the Applicant shall incorporate the specification of the entry gate into design and print the text of this condition as "Fire Department Notes" on plans.

Prior to requesting a final building inspection, the Applicant shall complete the installation of the entry gate and obtain fire department approval the final fire inspection.

25. FIRE019 - DEFENSIBLE SPACE REQUIREMENTS - (STANDARD)

Responsible Department: Fire

Condition/Mitigation Monitoring Measure: Manage combustible vegetation from within a minimum of 100 feet of structures, or to the property line, whichever is closer. Trim tree limbs to a minimum height of 6 feet from the ground. Remove tree limbs from within 10 feet of chimneys. Additional and/or alternate fire protection or firebreaks approved by the fire authority may be required to provide reasonable fire safety. Environmentally sensitive areas may require alternative fire protection, to be determined by Reviewing Authority and the Director of Planning and Building Inspection. Monterey County Regional Fire Protection District

-- (Condition No.25, PLN080350) --

Compliance or Monitoring Action to be Performed: Prior to issuance of grading and/or building permit, Applicant shall incorporate specification into design and print the text of this condition as "Fire Dept. Notes" on construction plans.

Prior to requesting a final building inspection, the Applicant shall complete the vegetation management and shall obtain fire department approval of the final fire inspection.

26. FIRE022 - FIRE PROTECTION EQUIPMENT & SYSTEMS - FIRE SPRINKLER SYSTEM - (HAZARDOUS CONDITIONS)

Responsible Department: Fire

Condition/Mitigation Monitoring Measure: The building(s) and attached garage(s) shall be fully protected with automatic fire sprinkler system(s). Installation shall be in accordance with the applicable NFPA standard. A minimum of four (4) sets of plans for fire sprinkler systems must be submitted by a California licensed C-16 contractor and approved prior to installation. This requirement is not intended to delay issuance of a building permit. A rough sprinkler inspection must be scheduled by the installing contractor completed prior to requesting a framing inspection. Due to substandard access, or other mitigating factors, small bathroom(s) and open attached porches, carports, and similar structures shall be protected with fire sprinklers. Monterey County Regional Fire Protection District

-- (Condition No. 26, PLN080350) --

Compliance or Monitoring Action to be Performed: Prior to issuance of grading and/or building permit, Applicant shall print the text of this condition as "Fire Dept. Notes" on construction plans.

Prior to requesting a framing inspection, the Applicant shall obtain fire department approval of the rough sprinkler inspection.

Prior to requesting a final building inspection, the Applicant shall complete the installation of the fire sprinkler system and obtain fire department approval of the final fire sprinkler inspection.

27. FIRE024 - FIRE ALARM SYSTEM - (SINGLE FAMILY DWELLING)

Responsible Department: Fire

Condition/Mitigation Monitoring Measure: The residence shall be fully protected with an approved household fire warning system as defined by NFPA Standard 72. Plans and specifications for the household fire warning system shall be submitted by a California licensed C-10 contractor and approved prior to installation. Household fire warning systems installed in lieu of single-station smoke alarms required by the Uniform Building Code shall be required to be placarded as permanent building equipment. Monterey County Regional Fire Protection District

-- (Condition No. 27, PLN080350) --

Compliance or Monitoring Action to be Performed: Prior to issuance of building permit, Applicant shall print the text of this condition on the construction plans.

Prior to requesting a framing inspection, Applicant shall obtain fire department approval of the fire alarm system plans.

Prior to requesting a final building inspection, Applicant shall complete the installation of the fire alarm system, obtain fire department approval of the fire alarm acceptance test and final fire inspection.

28. FIRE027 - ROOF CONSTRUCTION - (VERY HIGH HAZARD SEVERITY ZONE)

Responsible Department: Fire

Condition/Mitigation Monitoring Measure: All new structures, and all existing structures receiving new roofing over 50 percent or more of the existing roof surface within a one-year period, shall require a minimum of ICBO Class A roof construction. Monterey County Regional Fire Protection District

-- (Condition No. 28, PLN080350) --

Compliance or Monitoring Action to be Performed: Prior to issuance of building permit, the Applicant shall print the text of this condition as "Fire Dept. Notes" on construction plans.

29. FIRE011 - ADDRESSES FOR BUILDINGS

Responsible Department: Fire

Condition/Mitigation Monitoring Measure: All buildings shall be issued an address in accordance with Monterey County Ordinance No. 1241. Each occupancy, except accessory buildings, shall have its own permanently posted address. When multiple occupancies exist within a single building, each individual occupancy shall be separately identified by its own address. Letters, numbers and symbols for addresses shall be a minimum of 4-inch height, 1/2-inch stroke, contrasting with the background color of the sign, and shall be Arabic. The sign and numbers shall be reflective and made of a noncombustible material. Address signs shall be placed at each driveway entrance and at each driveway split. Address signs shall be visible and legible from both directions of travel along the road. In all cases, the address shall be posted at the beginning of construction and shall be maintained thereafter. Address signs along one-way roads shall be visible from both directions of travel. Where multiple addresses are required at a single driveway, they shall be mounted on a single sign. Where a roadway provides access solely to a single commercial occupancy, the address sign shall be placed at the nearest road intersection providing access to that site. Permanent address numbers shall be posted prior to requesting final clearance. Monterey County Regional Fire Protection District

Compliance or Monitoring Action to be Performed: Prior to issuance of building permit, Applicant shall incorporate specification into design and print the text of this condition as "Fire Dept. Notes" on plans.

Prior to requesting a final building inspection, Applicant shall install the required address signage and shall obtain fire department approval of the fire department final inspection.

30. NON-STANDARD CONDITION - HYDRANTS AND FIRE FLOW

Responsible Department: Fire

Condition/Mitigation Monitoring Measure: Hydrants for fire protection shall be provided at locations approved by the fire code official and shall conform to the following requirements:

- a. FIRE FLOW - Pursuant to California Fire Code Appendix B, the minimum fire flow requirement for _____ square foot commercial facilities built with Type ____ construction is _____ gallons per minute with a residual pressure of 20 psi under normal operating conditions for a duration of ____ hours. Fire flow for facilities protected with automatic fire sprinkler systems may be reduced to _____ gallons per minute with a residual pressure of 20 psi under normal operating conditions for a duration of ____ hours.
 - b. TIMING OF INSTALLATION - Approved fire protection water supply systems must be installed and made serviceable prior to the time of construction.
 - c. HYDRANT/FIRE VALVE (ADDITION) - New hydrant(s) shall be installed as determined by the fire code official.
 - d. HYDRANT/FIRE VALVE (LOCATION) - The hydrant or fire valve shall be 18 inches above grade, 8 feet from flammable vegetation, no closer than 4 feet nor further than 12 feet from a roadway, and in a location where fire apparatus using it will not block the roadway.
 - e. FIRE HYDRANTS - Hydrants shall be installed in accordance with spacing set forth in California Fire Code Appendix B and in accordance with the following specifications:
 - f. HYDRANT SIZE - The hydrant shall have a minimum of two (2) inch outlets NST and one (1) inch outlet NST. The riser shall be a minimum of six (6) inches and shall be wet barrel type with a coefficient of 0.9.
 - g. SIGNING OF WATER SOURCES - Hydrant or fire valve identification may be allowed as specified in the State Fire Marshall's Guidelines for Fire Hydrant Markings Along State Highways and Freeways, May 1988.
- Monterey County Regional Fire Protection District

Compliance or Monitoring Action to be Performed: Prior to issuance of building permit, the Applicant shall print the text of this condition as "Fire Department Notes" on the improvement plans and/or construction plans, shall complete the installation of water system improvements and shall obtain fire department approval of the water system acceptance test.

NOTES

- GENERAL**
1. Project shall comply with the 2007 California Building, Plumbing, Mechanical, Electrical, Fire and Energy Codes and all other codes that shall be placed underground.
 2. Fire sprinklers under separate permit.
 3. Hazardous waste under separate permit.
 4. A separate permit is required for grading (CBC Appendix 3306).

NOTIFICATIONS

- Notify the State Engineer 48 hours before the following dates:
1. After foundation construction is completed.
 2. After foundation construction is completed and before placing reinforcing steel and formwork.
 3. Prior to all concrete pours.
- Notify the Structural Engineer 48 hours before the following dates:
1. After the final formwork is placed and before placing reinforcing steel and formwork.
 2. Prior to all concrete pours.
 3. Prior to placing the last course of concrete rebar.
 4. Prior to placing any plywood sheathing on walls.
 5. Prior to covering any slabs with hold-down anchors.
 6. Prior to covering any slabs with hold-down anchors.
- Contact County Fire Department for inspection requirements.

SPECIAL INSPECTIONS

1. All special inspections shall be in accordance with Section 1709 of the Uniform Building Code.
2. Required for all foundation work.
3. Required for all foundation of a special structure in excess of 1200 sq. ft.

TREE PROTECTION AND REPLACEMENT

1. All native trees within 25 ft. of proposed ground disturbances shall be temporarily fenced with 1/2" mesh wire mesh and a 4' high barrier to prevent damage to the tree during construction activities. The fence shall be installed at least 6 ft. from the trunk of the tree and shall be marked every 6 ft. to the maximum extent possible.
2. The construction equipment shall be marked, staked, or placed within 6 ft. of any native tree within 6 ft. of the tree trunk.
3. Any native trees that are damaged or removed shall be replaced with a tree of the same or greater size and species as the original tree.
4. Any trees that are damaged or removed shall be replaced with a tree of the same or greater size and species as the original tree.
5. Any trees that are damaged or removed shall be replaced with a tree of the same or greater size and species as the original tree.
6. Any trees that are damaged or removed shall be replaced with a tree of the same or greater size and species as the original tree.
7. Any trees that are damaged or removed shall be replaced with a tree of the same or greater size and species as the original tree.
8. Any trees that are damaged or removed shall be replaced with a tree of the same or greater size and species as the original tree.
9. Any trees that are damaged or removed shall be replaced with a tree of the same or greater size and species as the original tree.
10. Any trees that are damaged or removed shall be replaced with a tree of the same or greater size and species as the original tree.

STRUCTURAL

SPECIAL INSPECTIONS

- In accordance with the California Building Code (CBC) Section 1905.0, the contractor shall provide the following special inspections:
1. Inspect the foundation and footing for proper placement and consolidation of concrete.
 2. Inspect the foundation and footing for proper placement and consolidation of concrete.
 3. Inspect the foundation and footing for proper placement and consolidation of concrete.
 4. Inspect the foundation and footing for proper placement and consolidation of concrete.
 5. Inspect the foundation and footing for proper placement and consolidation of concrete.
 6. Inspect the foundation and footing for proper placement and consolidation of concrete.
 7. Inspect the foundation and footing for proper placement and consolidation of concrete.
 8. Inspect the foundation and footing for proper placement and consolidation of concrete.
 9. Inspect the foundation and footing for proper placement and consolidation of concrete.
 10. Inspect the foundation and footing for proper placement and consolidation of concrete.

SOILS

SPECIAL INSPECTIONS

1. Inspect the foundation and footing for proper placement and consolidation of concrete.
2. Inspect the foundation and footing for proper placement and consolidation of concrete.
3. Inspect the foundation and footing for proper placement and consolidation of concrete.
4. Inspect the foundation and footing for proper placement and consolidation of concrete.
5. Inspect the foundation and footing for proper placement and consolidation of concrete.
6. Inspect the foundation and footing for proper placement and consolidation of concrete.
7. Inspect the foundation and footing for proper placement and consolidation of concrete.
8. Inspect the foundation and footing for proper placement and consolidation of concrete.
9. Inspect the foundation and footing for proper placement and consolidation of concrete.
10. Inspect the foundation and footing for proper placement and consolidation of concrete.

SPECIAL INSPECTIONS

Item No.	Description	Inspected By	Date
1	Foundation and footing		
2	Foundation and footing		
3	Foundation and footing		
4	Foundation and footing		
5	Foundation and footing		
6	Foundation and footing		
7	Foundation and footing		
8	Foundation and footing		
9	Foundation and footing		
10	Foundation and footing		

SHEET INDEX

ARCHITECTURAL

- A0 Vicinity map, Project Data, Specifications & Notes
- A1 Foundation and Footing Plan
- A2 Foundation and Footing Plan
- A3 Foundation and Footing Plan
- A4 Foundation and Footing Plan
- A5 Foundation and Footing Plan
- A6 Foundation and Footing Plan
- A7 Foundation and Footing Plan
- A8 Foundation and Footing Plan
- A9 Foundation and Footing Plan
- A10 Foundation and Footing Plan
- A11 Foundation and Footing Plan
- A12 Foundation and Footing Plan
- A13 Foundation and Footing Plan
- A14 Foundation and Footing Plan
- A15 Foundation and Footing Plan
- A16 Foundation and Footing Plan
- A17 Foundation and Footing Plan
- A18 Foundation and Footing Plan
- A19 Foundation and Footing Plan
- A20 Foundation and Footing Plan
- A21 Main Residence First Floor Plan
- A22 Main Residence Garage & Second Floor Plan
- A23 Main Residence Roof Plan
- A24 Main Residence Roof Plan
- A25 Main Residence Roof Plan
- A26 Main Residence Roof Plan
- A27 Main Residence Roof Plan
- A28 Main Residence Roof Plan
- A29 Main Residence Roof Plan
- A30 Main Residence Roof Plan
- A31 Main Residence Roof Plan
- A32 Main Residence Roof Plan
- A33 Main Residence Roof Plan
- A34 Main Residence Roof Plan
- A35 Main Residence Roof Plan
- A36 Main Residence Roof Plan
- A37 Main Residence Roof Plan
- A38 Main Residence Roof Plan
- A39 Main Residence Roof Plan
- A40 Main Residence Roof Plan
- A41 Main Residence Roof Plan
- A42 Main Residence Roof Plan
- A43 Main Residence Roof Plan
- A44 Main Residence Roof Plan
- A45 Main Residence Roof Plan
- A46 Main Residence Roof Plan
- A47 Main Residence Roof Plan
- A48 Main Residence Roof Plan
- A49 Main Residence Roof Plan
- A50 Main Residence Roof Plan
- A51 Main Residence Roof Plan
- A52 Main Residence Roof Plan
- A53 Main Residence Roof Plan
- A54 Main Residence Roof Plan
- A55 Main Residence Roof Plan
- A56 Main Residence Roof Plan
- A57 Main Residence Roof Plan
- A58 Main Residence Roof Plan
- A59 Main Residence Roof Plan
- A60 Main Residence Roof Plan
- A61 Main Residence Roof Plan
- A62 Main Residence Roof Plan
- A63 Main Residence Roof Plan
- A64 Main Residence Roof Plan
- A65 Main Residence Roof Plan
- A66 Main Residence Roof Plan
- A67 Main Residence Roof Plan
- A68 Main Residence Roof Plan
- A69 Main Residence Roof Plan
- A70 Main Residence Roof Plan
- A71 Main Residence Roof Plan
- A72 Main Residence Roof Plan
- A73 Main Residence Roof Plan
- A74 Main Residence Roof Plan
- A75 Main Residence Roof Plan
- A76 Main Residence Roof Plan
- A77 Main Residence Roof Plan
- A78 Main Residence Roof Plan
- A79 Main Residence Roof Plan
- A80 Main Residence Roof Plan
- A81 Main Residence Roof Plan
- A82 Main Residence Roof Plan
- A83 Main Residence Roof Plan
- A84 Main Residence Roof Plan
- A85 Main Residence Roof Plan
- A86 Main Residence Roof Plan
- A87 Main Residence Roof Plan
- A88 Main Residence Roof Plan
- A89 Main Residence Roof Plan
- A90 Main Residence Roof Plan
- A91 Main Residence Roof Plan
- A92 Main Residence Roof Plan
- A93 Main Residence Roof Plan
- A94 Main Residence Roof Plan
- A95 Main Residence Roof Plan
- A96 Main Residence Roof Plan
- A97 Main Residence Roof Plan
- A98 Main Residence Roof Plan
- A99 Main Residence Roof Plan
- A100 Main Residence Roof Plan

STRUCTURAL

MECHANICAL

ELECTRICAL

LANDSCAPE

- L10 Preliminary Site Plan
- L11 Landscape Irrigation Plan
- L12 Final Landscape Irrigation Plan
- L13 Final Landscape Irrigation Plan
- L14 Final Landscape Irrigation Plan
- L15 Final Landscape Irrigation Plan
- L16 Final Landscape Irrigation Plan
- L17 Final Landscape Irrigation Plan
- L18 Final Landscape Irrigation Plan
- L19 Final Landscape Irrigation Plan
- L20 Final Landscape Irrigation Plan
- L21 Final Landscape Irrigation Plan
- L22 Final Landscape Irrigation Plan
- L23 Final Landscape Irrigation Plan
- L24 Final Landscape Irrigation Plan
- L25 Final Landscape Irrigation Plan
- L26 Final Landscape Irrigation Plan
- L27 Final Landscape Irrigation Plan
- L28 Final Landscape Irrigation Plan
- L29 Final Landscape Irrigation Plan
- L30 Final Landscape Irrigation Plan
- L31 Final Landscape Irrigation Plan
- L32 Final Landscape Irrigation Plan
- L33 Final Landscape Irrigation Plan
- L34 Final Landscape Irrigation Plan
- L35 Final Landscape Irrigation Plan
- L36 Final Landscape Irrigation Plan
- L37 Final Landscape Irrigation Plan
- L38 Final Landscape Irrigation Plan
- L39 Final Landscape Irrigation Plan
- L40 Final Landscape Irrigation Plan

CONSULTANTS

- ARCHITECT**
 Norman Harb
 720 York Street, #114
 San Diego, CA 92109
 PH: 619.444.1397
- LANDSCAPE ARCHITECT**
 Norman Harb
 720 York Street, #114
 San Diego, CA 92109
 PH: 619.444.1397
- SOILS ENGINEERS**
 Srinivasan Swamy
 11111 Camino del Rio South, #1111
 San Diego, CA 92108
 PH: 619.594.1030
- MECHANICAL ENGINEERS**
 Srinivasan Swamy
 11111 Camino del Rio South, #1111
 San Diego, CA 92108
 PH: 619.594.1030

VICINITY MAP

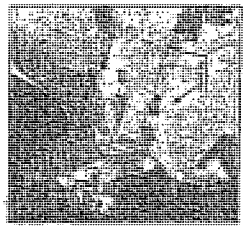

PROJECT DATA

PROJECT ADDRESS
 8 Goodrich Trail
 Carmel, California 93923

OWNER
 Gary & Helen Taylor
 11235 W. Pecos Road
 Canyon, WI 53517

SCOPE OF WORK
 Complete new two-story single family residence with attached garage, separate entry, and pool.

PROPOSED STRUCTURES
 8230 SF SFD, 1000 SF Garage, 840 SF Entry, 1055 SF Pool.

BUILDING CODE DATA LEGEND

Company Group	U-I-R-3
Structure <td>V8 - Non-reinforced concrete</td>	V8 - Non-reinforced concrete
Roof <td>V2</td>	V2
Height (above 6' grade) <td>4.28 ft.</td>	4.28 ft.
Residence Deck <td>8230 SF</td>	8230 SF
Residence Deck <td>1000 SF</td>	1000 SF
Garage Deck <td>840 SF</td>	840 SF
Entry Deck <td>1055 SF</td>	1055 SF
Pool Deck <td>1055 SF</td>	1055 SF
Pool Deck <td>1055 SF</td>	1055 SF

ZONING DATA

APN
 238-102-01-1000

ZONE
 R-100 (Residential Single-Family)

HEIGHT & SETBACK REGULATIONS
 PH: Monterey Co. 04.71.2009

Front
 30 ft.

Side
 20 ft.

Max. Ht.
 32 ft.

Accessory Structures (Detached)
 9 ft.

Max. Ht.
 8 ft.

Max. Ht.
 35 ft.

Accessory Structures (Attached)
 50 ft.

Front
 5 ft.

Side
 5 ft.

Max. Ht.
 35 ft.

CONSTITUTION

CONSTITUTION
 Yes, under separate permit. Plans include foundation, and maintenance as approved by Monterey County Fire Chief.

SPRINKLERS
 240 Cu. Yds.
 75 Cu. Yds.
 165 Cu. Yds.

GRAVING
 6666 SF = 0.4%
 8126 SF = 0.6%
 21,000 SF = 1.4%

LOT COVERAGE
 FAR
 IMPERVIOUS



NOT FOR CONSTRUCTION

GENERAL NOTES

1. All work shall be in accordance with the provisions of the International Building Code, 2003 Edition, and the Florida Building Code, 2003 Edition, as amended by all applicable amendments.
2. Refer to all drawings for utility, drainage and other related information.
3. Refer to all drawings for details.

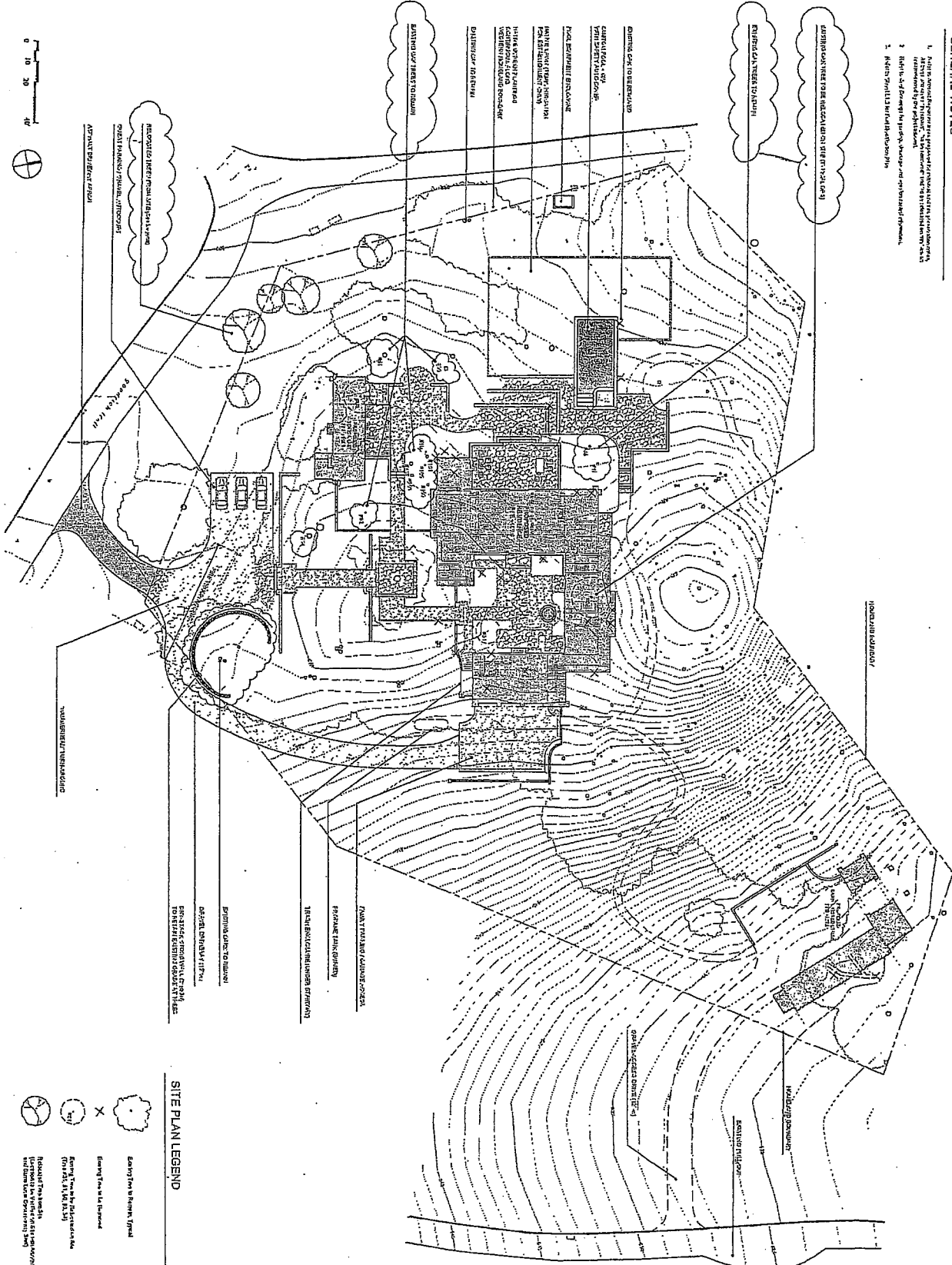

PROPERTY BOUNDARY

EXISTING POOL

EXISTING DRIVEWAY

REMOVE EXISTING POOL TO CLEAR

REMOVE EXISTING DRIVEWAY TO CLEAR

REMOVE EXISTING POOL TO CLEAR

REMOVE EXISTING DRIVEWAY TO CLEAR

REMOVE EXISTING POOL TO CLEAR

REMOVE EXISTING DRIVEWAY TO CLEAR

REMOVE EXISTING POOL TO CLEAR

REMOVE EXISTING DRIVEWAY TO CLEAR

REMOVE EXISTING POOL TO CLEAR

REMOVE EXISTING DRIVEWAY TO CLEAR

DATE: October 20, 2008
 SCALE: 1" = 20'-0"
 SHEET: L1.1

TAYLOR RESIDENCE

LAURA
 Santa Lucia Preserve
 Central, Colorado
 Residential / House
 J.W. Tyler
 The Bluebird
 1000 Bluebird Lane
 Fort Collins, Colorado

Site Plan

L1.1

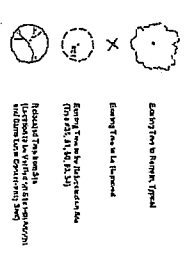

RESTORATION SEED MIX

Symbol	Botanical Name	Common Name	Qty/Size	Notes
○	BRUGSIA BRUGSII	Woodland Green Grass	9	seed
○	DAVIDSONIA INFERNA	California Poppy	1	seed
○	LUPULUS	Sty Lupine	7	seed
○	HELIOPSIS	Woolly Star	10	seed
○	HELIOPSIS	Woodland Green	15	seed
○	HELIOPSIS	Poppy Green Grass	15	seed
○	HELIOPSIS	Paint Pot	5	seed

NOTE:
 1. All plants are native to California.
 2. Seed quantities are based on a 10% germination rate.
 3. All quantities are based on a 10% germination rate.
 4. All quantities are based on a 10% germination rate.

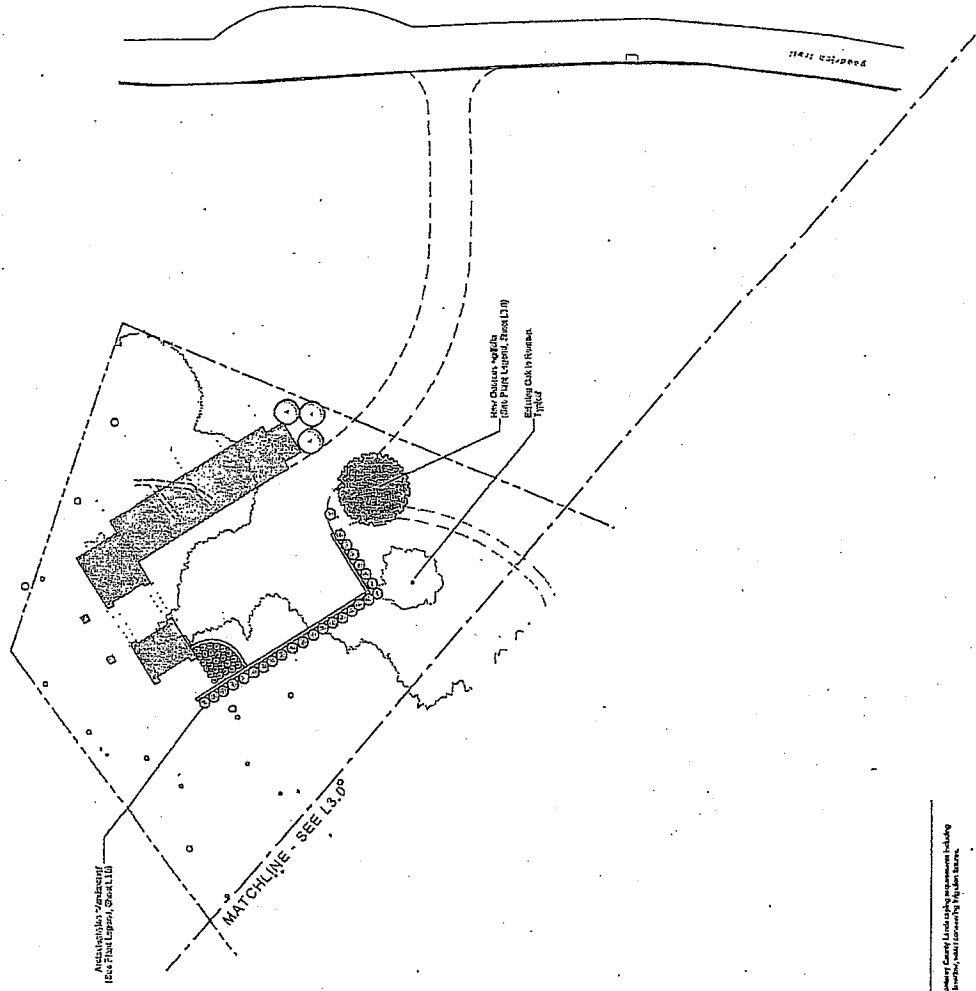

LANDSCAPE STATEMENT

This plan shows the proposed landscape design for the site. It is based on the site conditions and the client's requirements. The design is intended to provide a functional and aesthetically pleasing outdoor environment.

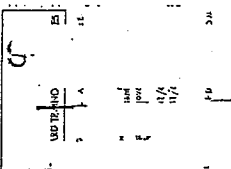
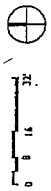

TAYLOR RESIDENCE

101514
 San Diego, CA 92121

Revisions / Notes
 Jan 1, 2007

Planting Plan

Date: October 30, 2006
 Scale: 1/8" = 1'-0"

Sheet: **L3.1**

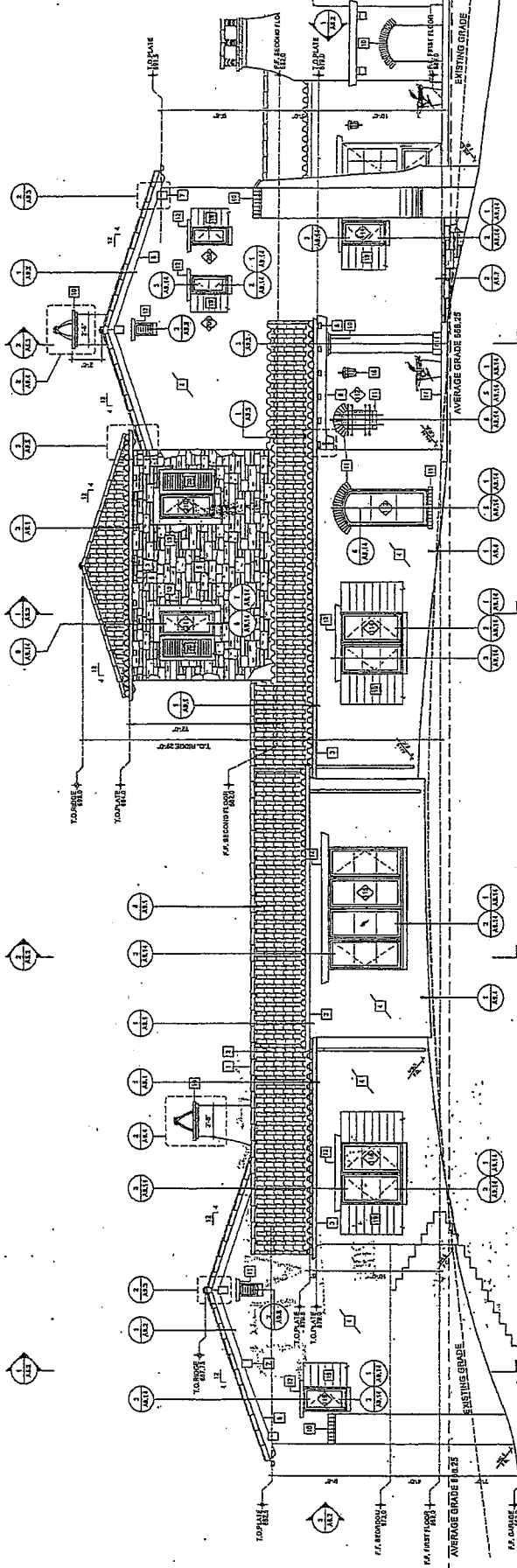

02
MAIN RESIDENCE ELEVATION - NORTH
SCALE 1/8" = 1'-0"

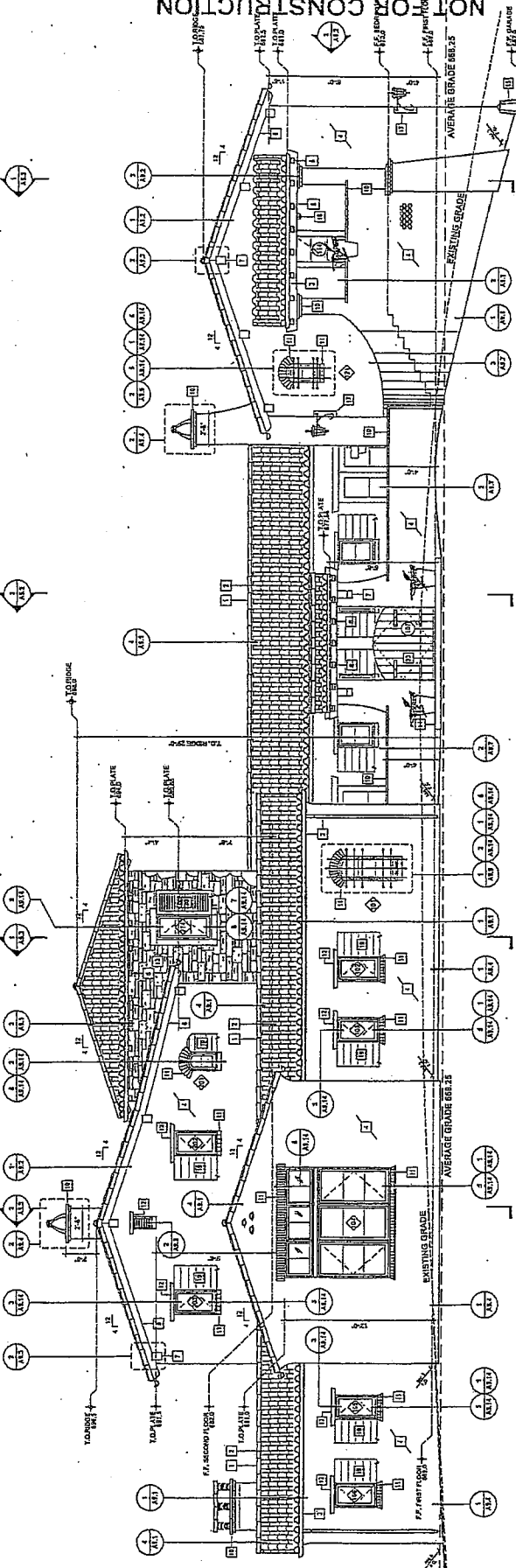

01
MAIN RESIDENCE ELEVATION - SOUTH
SCALE 1/8" = 1'-0"

TAYLOR RESIDENCE
8 GOODRICH TRAIL
CARMEL, CALIFORNIA 93923

MAIN RESIDENCE
EXTERIOR
ELEVATIONS



DATE: 11/11/11

A6.1

NOT FOR CONSTRUCTION

TOM MEAKY
822 STATE STREET SUITE 240 SANTA BARBARA, CA 93101

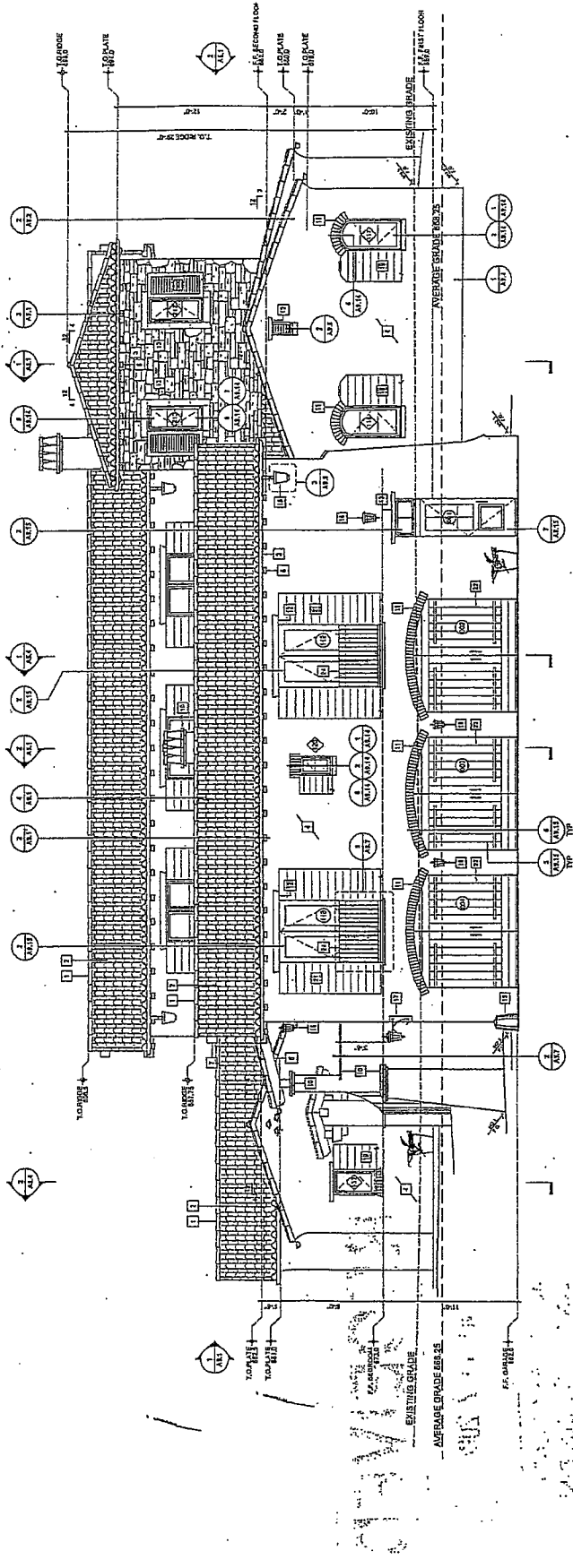

MAIN RESIDENCE ELEVATION - EAST
SCALE: 1/8" = 1'-0"

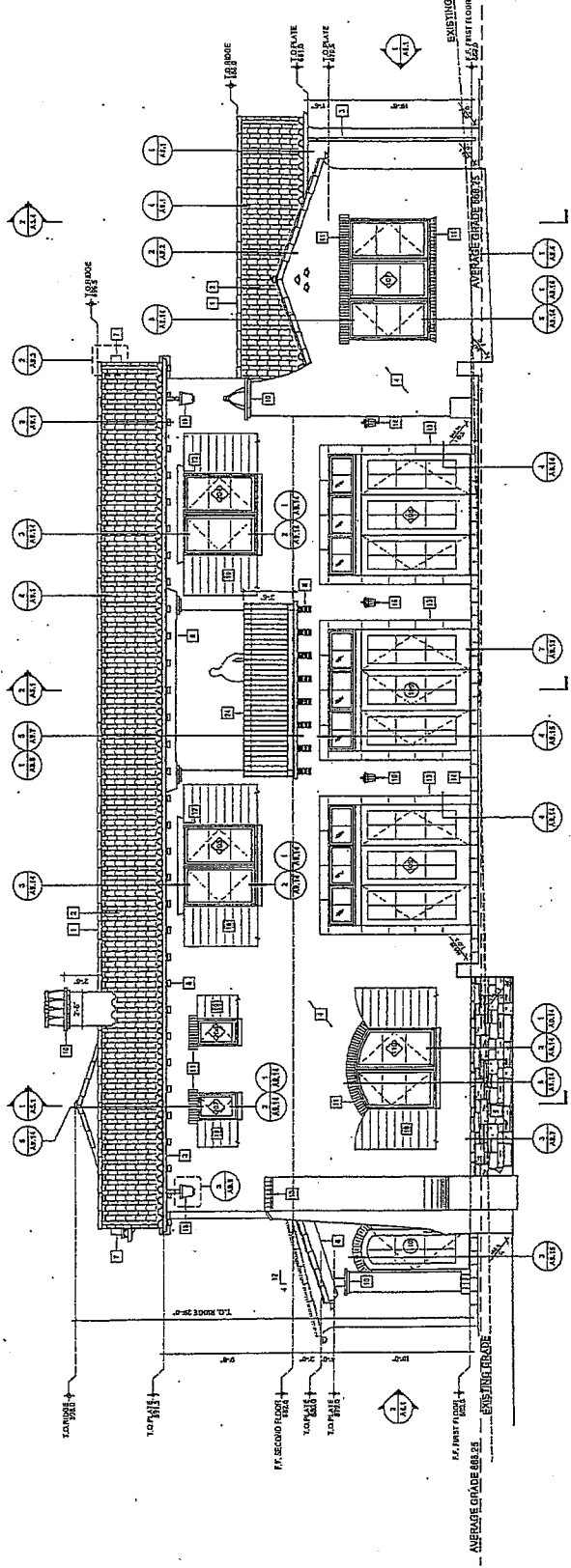

MAIN RESIDENCE ELEVATION - WEST
SCALE: 1/8" = 1'-0"

NOT FOR CONSTRUCTION

TAYLOR RESIDENCE
8 GOODRICH TRAIL
CARMEL, CALIFORNIA 93923



OCT 1984

TOM HEALEY A.R.C.
459 STATE STREET SUITE 240 SANTA BARBARA, CA

A6.2

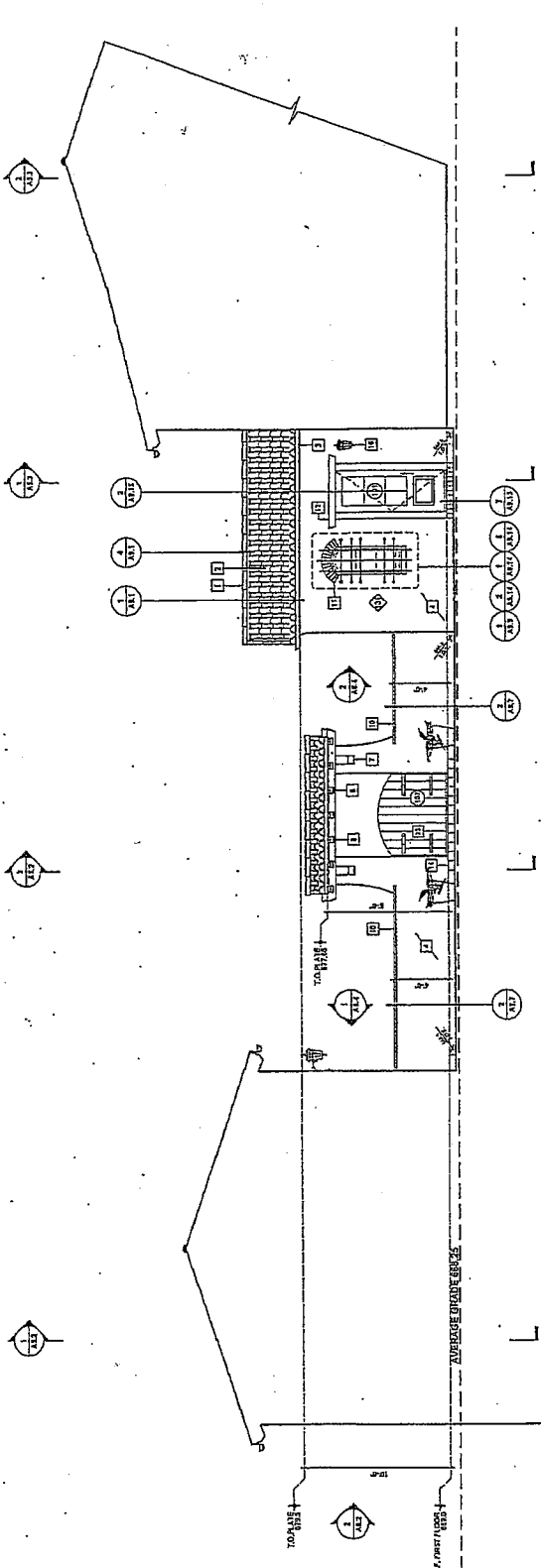

MAIN RESIDENCE INTERIOR COURTYARD ELEVATION - NORTH
SECTION 02

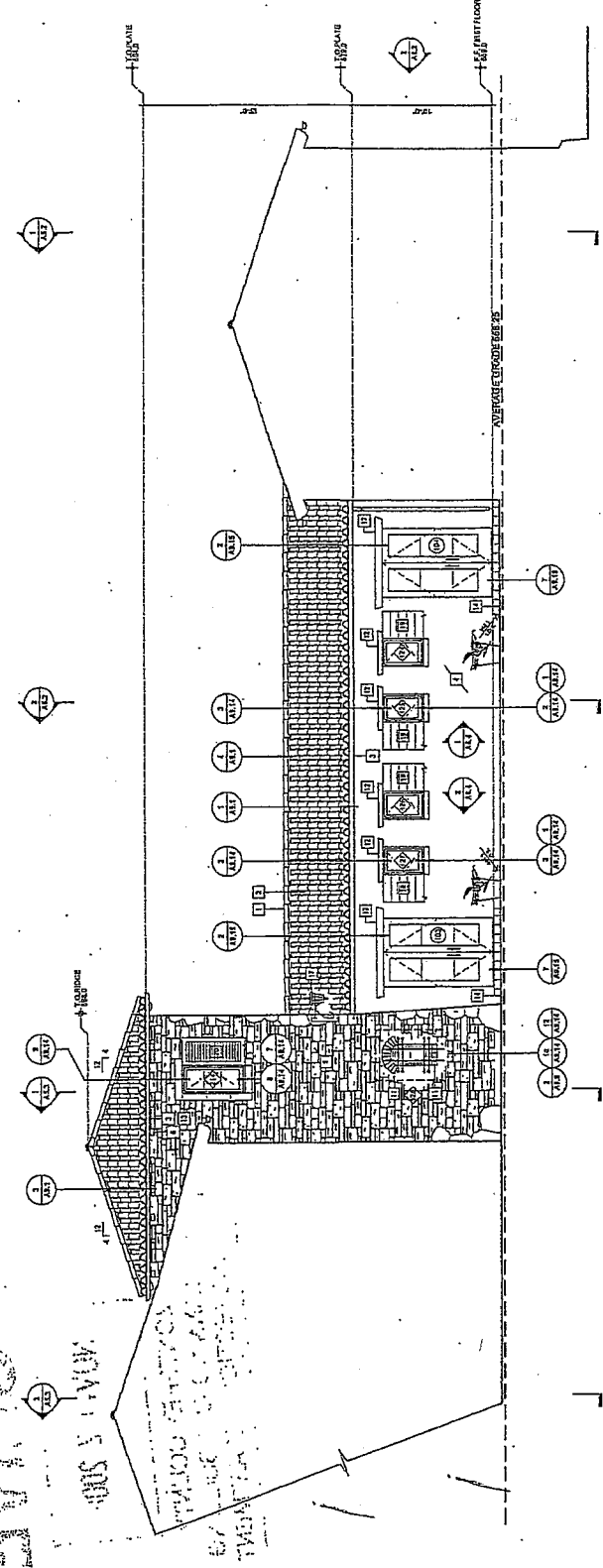

MAIN RESIDENCE INTERIOR COURTYARD ELEVATION - SOUTH
SECTION 01

NOT FOR CONSTRUCTION

TAYLOR RESIDENCE
8 GOODRICH TRAIL
CARMEL, CALIFORNIA 93923

MAIN RESIDENCE
ELEVATIONS



OCT 2008

A6.3

TOM KEARNEY
325 STATE STREET SUITE 240 SANTA BARBARA, CA 93101 TEL: 805.964.2424

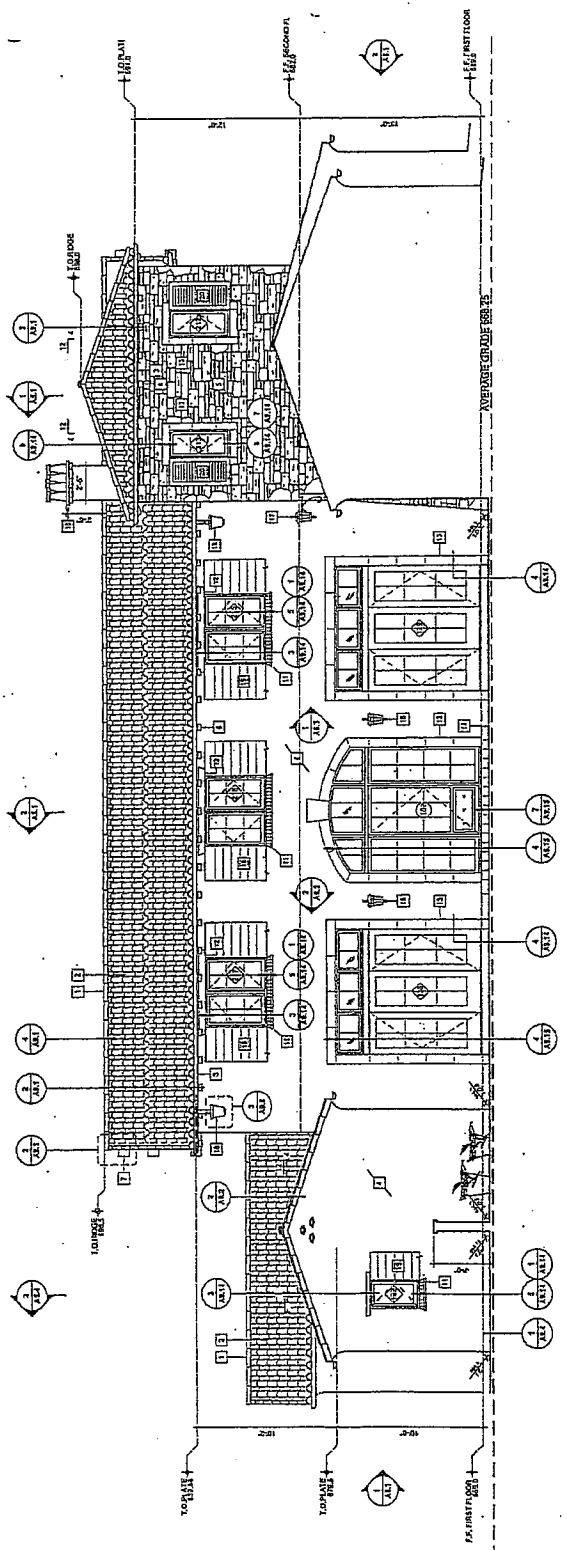

MAIN RESIDENCE INTERIOR COURTYARD ELEVATION - EAST
SCALE: 1/8" = 1'-0"

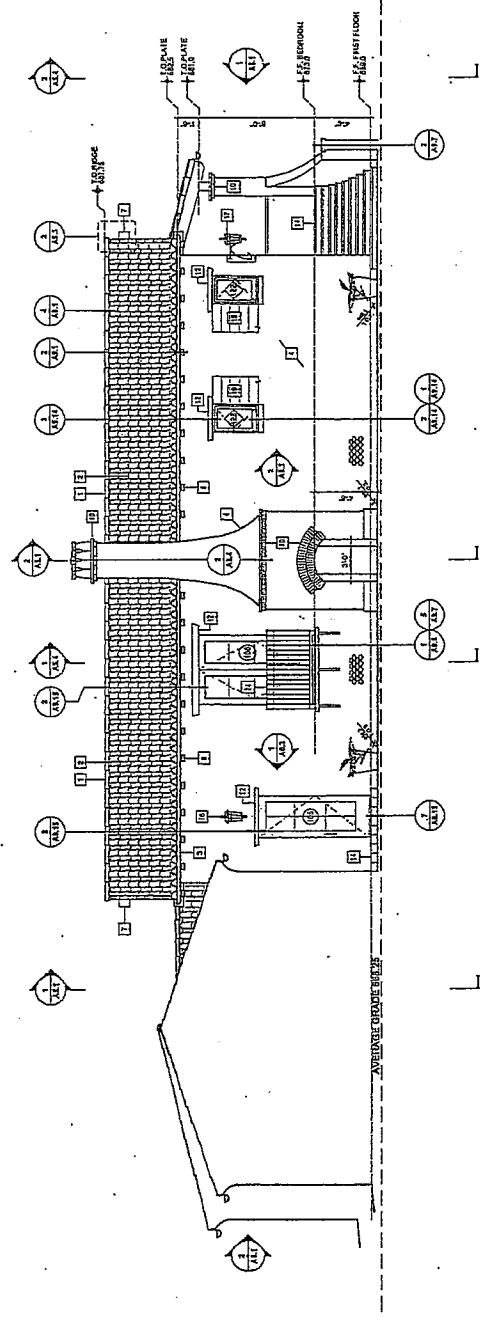

MAIN RESIDENCE INTERIOR COURTYARD ELEVATION - WEST
SCALE: 1/8" = 1'-0"

NOT FOR CONSTRUCTION



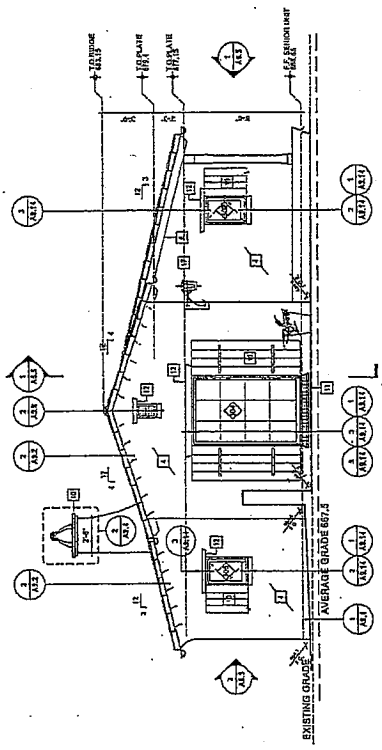

SENIOR UNIT ELEVATION - EAST
SCALE 1/8" = 1'-0"

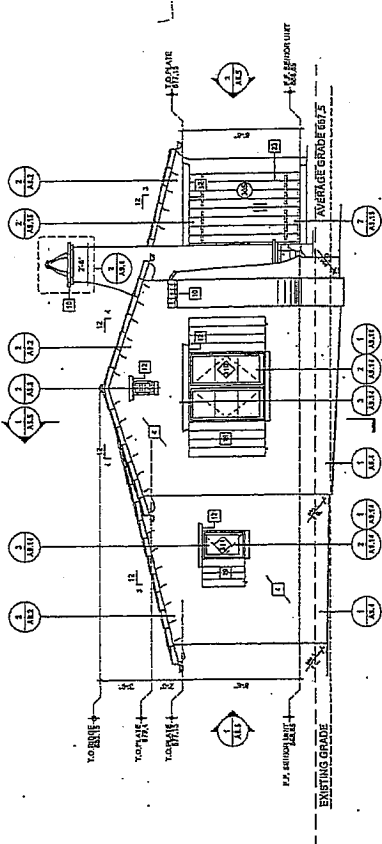

SENIOR UNIT ELEVATION - WEST
SCALE 1/8" = 1'-0"

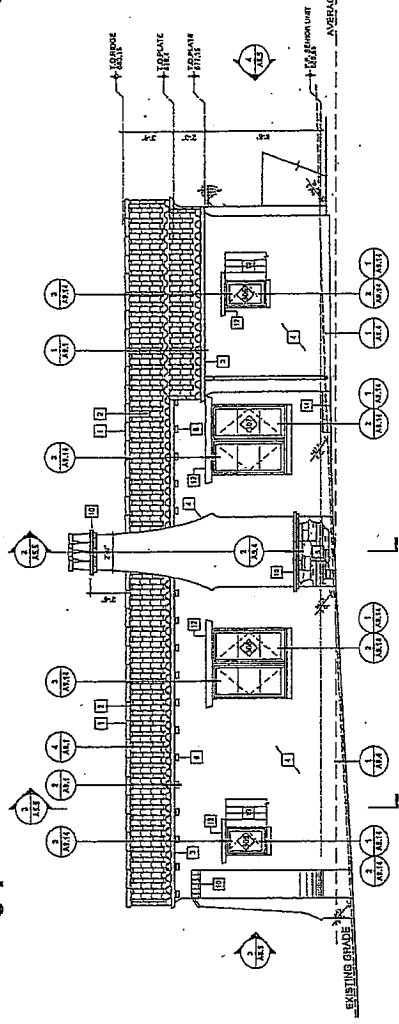

SENIOR UNIT ELEVATION - SOUTH
SCALE 1/8" = 1'-0"

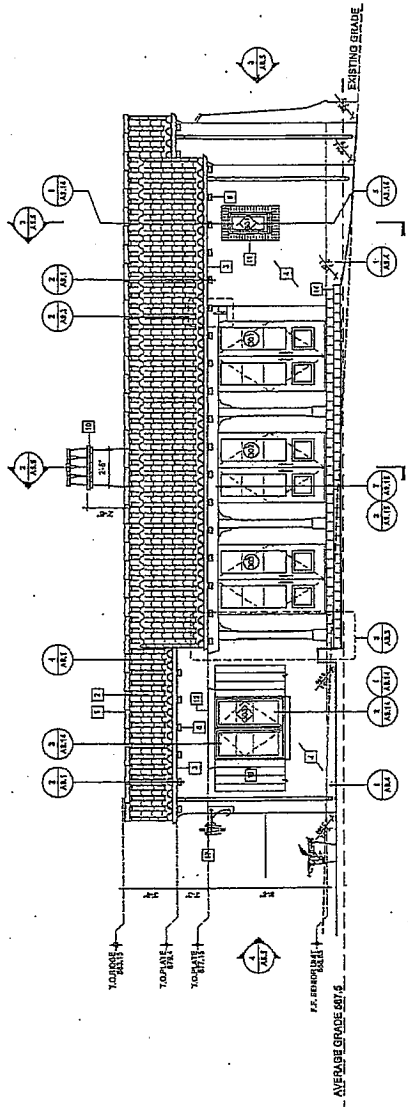

SENIOR UNIT ELEVATION - NORTH
SCALE 1/8" = 1'-0"

CAMERON
 ARCHITECTS
 223 STATE STREET SUITE 240 SANTA BARBARA, CA 93101
 TEL: 805.964.1100 FAX: 805.964.1101
 WWW.CAMERONARCHITECTS.COM

TAYLOR RESIDENCE
 8 GODRICH TRAIL
 CARMEL, CALIFORNIA 93923
 TOM KEANEY ARCHIT.



OCT 11 11 11 AM '11
 11 11 11 AM '11

NOT FOR CONSTRUCTION

A6.1

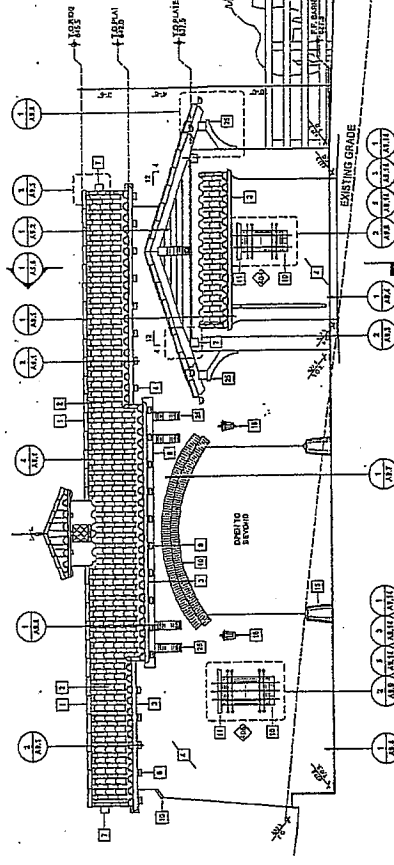

BARN ELEVATION - WEST
SCALE 1/4" = 1'-0"

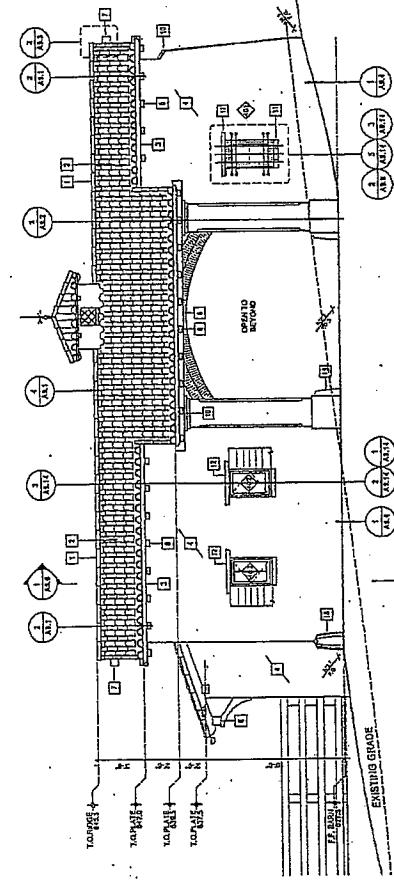

BARN ELEVATION - EAST
SCALE 1/4" = 1'-0"

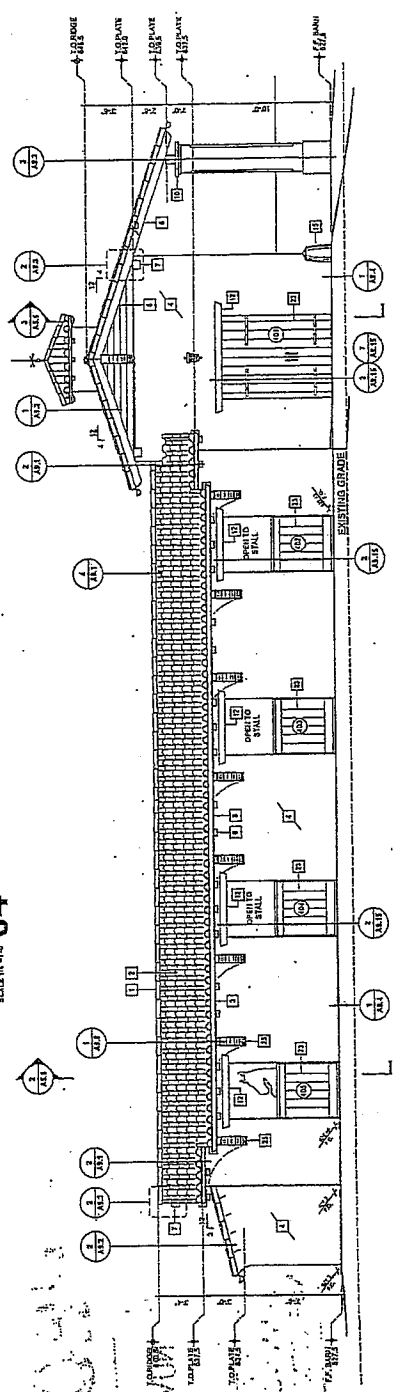

BARN ELEVATION - SOUTH
SCALE 1/4" = 1'-0"

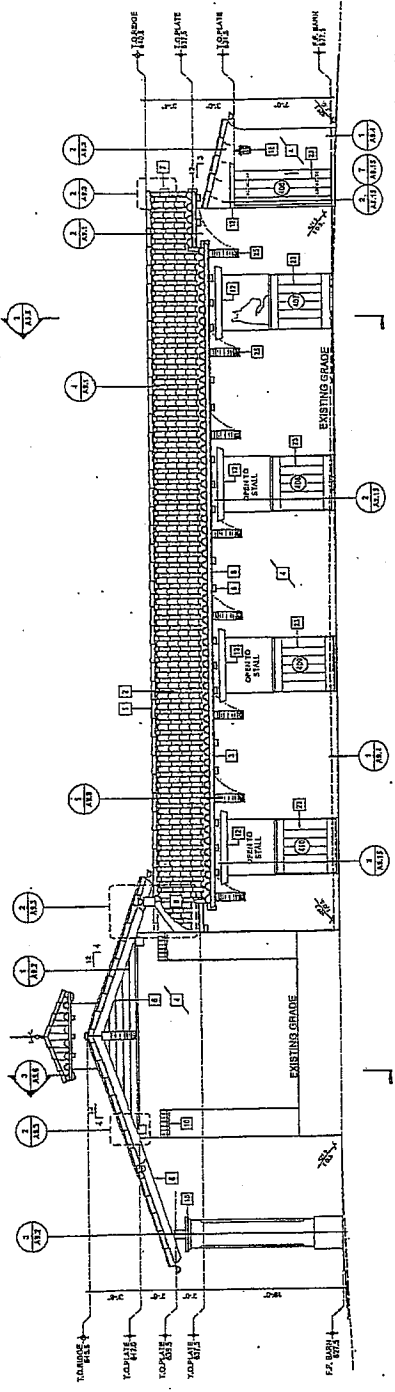

BARN ELEVATION - NORTH
SCALE 1/4" = 1'-0"

Handwritten notes:
 1. 185'0" TO 185'18"
 2. 185'0" TO 185'18"
 3. 185'0" TO 185'18"
 4. 185'0" TO 185'18"
 5. 185'0" TO 185'18"

NOT FOR CONSTRUCTION



TAYLOR RESIDENCE
 8 GODDICH TRAIL
 CARMEL, CALIFORNIA 93923

A6.6

01

PLN 130509

Laura Lawrence
Monterey County Resource Management Agency
Planning Department
Attn: Laura Lawrence
168 West Alisal 2nd Floor
Salinas, CA. 93901

July 5, 2013

RE: Planning Approval Extension
APN: 239-102-021-000
Res # 09040
PLN # 080350

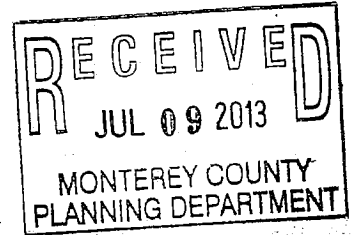

Dear Laura,

Thank you so much for helping me initiate the process of extending my permit on the above property. I purchased this property from the Taylor family and am asking for an extension to the permits that have been granted. Due to the short time period, construction concerns, and financing, I will need a three year extension period to determine what will eventually be built.

Thank you for your understanding and help in granting this extension. I have enclosed a check in the amount of \$5,093.39 for the extension as requested. I also took the liberty of filling out the extension application.

Please feel free to contact me should you have any further questions.

Best Regards

A handwritten signature in black ink, appearing to read "Paul Sallaberry".

Paul Sallaberry
435 Santa Rita Ave.
Menlo Park CA. 94025

**Before the Planning Commission in and for the
County of Monterey, State of California**

In the matter of the application of:

TAYLOR (PLN080350)

RESOLUTION NO. 09040

Resolution by the Monterey County Planning
Commission:

- 1) Consider the Addendum to the Environmental Impact Report for the Santa Lucia Preserve (EIR 94-005);
- 2) Approving a Combined Development Permit consisting of: 1) An Administrative Permit and Design Approval to allow the construction of a 6,230 square-foot two-story single family dwelling with an attached 1,000 square-foot three-car garage, a 1,055 square-foot barn, an 800 square-foot swimming pool, 15 garden walls totaling 580 linear feet; 2) A Use Permit to allow the removal of 11 oak trees and the re-location of 5 oak trees; and 3) An Administrative Permit to allow the construction of an 840 square-foot detached senior citizen unit with a 253 square-foot covered terrace and grading consisting of 240 cubic yards of cut and 75 cubic yards of fill.

(PLN080350, Taylor, 8 Goodrich Trail, Carmel, Carmel Valley Master Plan (APN: 239-102-021-000))

The Taylor Combined Development Permit application (PLN080350) came on for public hearing before the Monterey County Planning Commission on August 12, 2009. Having considered all the written and documentary evidence, the administrative record, the staff report, oral testimony, and other evidence presented, the Planning Commission finds and decides as follows:

FINDINGS

1. **FINDING:** **CONSISTENCY** – The Project, as conditioned, is consistent with the applicable plans and policies which designate this area as appropriate for development.

EVIDENCE: a) During the course of review of this application, the project has been reviewed for consistency with the text, policies, and regulations in:

- the Monterey County General Plan,
- Carmel Valley Master Plan,
- Monterey County Zoning Ordinance (Title 21)

No conflicts were found to exist. No communications were received during the course of review of the project indicating any inconsistencies with the text, policies, and regulations in these documents.

- b) The property is located at 8 Goodrich Trail, Carmel (Assessor's Parcel Number 239-102-021-000, Carmel Valley Master Plan. The parcel is zoned Rural Grazing, 10 acres per unit with Design Control, Site Plan

Exhibit C

Review and Residential Allocation Zoning district overlays or "RG/10-D-S-RAZ", which allows the construction of a single family dwelling, subject to an Administrative Permit. Therefore, the project is an allowed land use for the site.

- c) The project consists of the construction of a 6,230 square-foot two-story single family dwelling with an attached 1,000 square-foot three-car garage, a 1,055 square-foot barn, an 800 square-foot swimming pool and 15 garden walls totaling 580 linear feet. Such a use requires an Administrative Permit in accordance with Title 21, Section 21.45.040.B. The project also consists of the construction of an 840 square-foot detached senior citizen unit with a 253 square-foot covered terrace which requires an Administrative Permit in accordance with Section 21.32.040.B. The project results in the removal of 28 protected oak trees, 12 of which were approved for removal with the approval of the Potrero Subdivision and five of which are suitable for re-location on site. A total of 11 protected oak trees are proposed for removal for this project which requires a Use Permit in accordance with Section 21.64.260.D.3.a of Title 21. Staff has found the project consistent with the development standards of Sections 21.32.060, 21.64.260 and 21.64.010 of Title 21.
- d) The property is within a Design Control District overlay which requires additional design review of proposed structures within the District to assure protection of the public viewshed and neighborhood character without imposing undue restrictions on private property. In addition, Carmel Valley Master Plan Policy 26.1.26 requires that development is either visually compatible with the character of the valley, including the immediate surrounding areas, or shall enhance the quality of the areas which may have been degraded by existing development. The materials and colors proposed are: a plaster exterior with beige "Drennan" paint, windows, shutters, a garage door, gate and barn stalls of faint blue "Northern Light" paint and a terra cotta tile roof. Staff has determined that the project design, materials to be used, and colors chosen for the project are consistent and compatible with residences in the immediate area and blend in with the natural landscape of the property and therefore comply with the purpose of the Design Control District and meet the Carmel Valley Master Plan policy referenced above.
- e) The project planner conducted a site inspection on August 1, 2008 and June 19, 2009 to verify that the project on the subject parcel conforms to the plans listed above.
- f) The project was not referred to the Carmel Valley Land Use Advisory Committee (LUAC) for review. Based on the LUAC Procedure guidelines adopted by the Monterey County Board of Supervisors per Resolution No. 08-338, this application did not warrant referral to the LUAC because the project did not require an Initial Study or Environmental Impact Report.
- g) The application, project plans, and related support materials submitted by the project applicant to the Monterey County RMA - Planning Department for the proposed development found in Project File PLN080350.

2. **FINDING:** **SITE SUITABILITY** – The site is physically suitable for the use proposed.

- EVIDENCE:** a) The project has been reviewed for site suitability by the following departments and agencies: RMA - Planning Department, Carmel Valley Fire Protection District, Public Works, Environmental Health Division, and Water Resources Agency. There has been no indication from these departments/agencies that the site is not suitable for the proposed development. Conditions recommended have been incorporated.
- b) Staff identified potential impacts to Biological Resources (oak trees), and Soil/Slope Stability. Technical reports by outside consultants indicated that there are no physical or environmental constraints that would indicate that the site is not suitable for the use proposed. County staff independently reviewed these reports and concurs with their conclusions. The following reports have been prepared:
- “Construction Impacts Analysis” (LIB090351) prepared by Maureen Hamb-WCISA Certified Arborist #2280, Santa Cruz, California, October 1, 2008.
 - “Subsequent Construction Impacts Analysis” (LIB090350) prepared by Maureen Hamb-WCISA Certified Arborist #2280, Santa Cruz, California, March 9, 2009.
 - “Geotechnical Engineering Investigation” (LIB090352) prepared by Moore Twining Associates, INC., Fresno, California, July 11, 2008.

According to Monterey County Resource Maps, the parcel is located within an area of “moderate” archaeological sensitivity. The Archaeological Reconnaissance prepared for the Rancho San Carlos – Potrero project by Gary Breshini identifies cultural resources found at the Rancho. The referenced archaeological report did not identify any pre-historic, historic or archaeological sites on or in the immediate vicinity of the Taylor property. Condition of Approval number 4 requires that work be stopped within 50 meters (165 feet) in the event of a resource being uncovered and to contact the Monterey County RMA - Planning Department and a qualified archaeologist immediately if cultural, archaeological, historical or paleontological resources are uncovered. When contacted, the project planner and the archaeologist shall immediately visit the site to determine the extent of the resources and to develop proper mitigation measures required for the discovery.

- c) Staff conducted a site inspection on August 1, 2008 and June 19, 2009 to verify that the site is suitable for this use.
- d) The application, project plans, and related support materials submitted by the project applicant to the Monterey County RMA - Planning Department for the proposed development found in Project File PLN080350.

3. **FINDING:** **HEALTH AND SAFETY** - The establishment, maintenance, or operation of the project applied for will not under the circumstances of this particular case be detrimental to the health, safety, peace, morals, comfort, and general welfare of persons residing or working in the neighborhood of such proposed use, or be detrimental or injurious to

property and improvements in the neighborhood or to the general welfare of the County.

- EVIDENCE:** a) The project was reviewed by The Carmel Valley Fire Department, Public Works Department, Environmental Health Division and the Water Resources Agency. The respective departments/agencies have recommended conditions, where appropriate, to ensure that the project will not have an adverse effect on the health, safety, and welfare of persons either residing or working in the neighborhood.
- b) Necessary public facilities are available and will be provided. The project will receive water from the Santa Lucia Preserve Water System and will dispose of wastewater through a new septic system.
- c) Preceding findings and supporting evidence for PLN080350.

4. **FINDING:** **NO VIOLATIONS** - The subject property is in compliance with all rules and regulations pertaining to zoning uses, subdivision, and any other applicable provisions of the County's zoning ordinance. No violations exist on the property.

- EVIDENCE:** a) Staff reviewed Monterey County RMA - Planning Department and Building Services Department records and is not aware of any violations existing on subject property.
- b) Staff conducted a site inspection on August 1, 2008 and June 19, 2009 and researched County records to assess if any violation exists on the subject property.
- c) There are no known violations on the subject parcel.
- d) Zoning violation abatement costs, if any, have been paid. A condition is included to assure that all zoning abatement costs, if any, have been paid.
- e) The application, plans and supporting materials submitted by the project applicant to the Monterey County Planning Department for the proposed development are found in Project File PLN080350.

5. **FINDING:** **CEQA (Addendum):** - An Addendum to a previously certified EIR was prepared pursuant to Code of Regulations, Section 15164 to reflect changes or additions in the project that do not cause substantial changes or new information that would require major revisions to the adopted EIR.

- EVIDENCE:** a) A Supplemental EIR (SEIR) to the EIR prepared for the Santa Lucia Preserve Comprehensive Development (EIR 94-005) plan was prepared and certified for the Potrero Subdivision in 2003.
- b) An Addendum to the Santa Lucia Preserve EIR (94-005) was prepared pursuant to Code of Regulations, Section 15164 (CEQA Guidelines).
- c) Pursuant to Section 15162 of the CEQA Guidelines, there are no substantial changes proposed in the project that would require major revisions to the prior EIR. The SEIR to the Santa Lucia Preserve EIR was prepared to analyze potential impacts from the Potrero Subdivision. Condition of Approval number 25 of the Potrero Subdivision provided specific tree removal estimates for each lot created by the subdivision. The Taylor parcel, Lot E18 was allotted the removal of 12 protected trees when the Potrero subdivision was approved. The Taylor project would result in the removal of 28 protected oak trees. Of the 28 trees

12 were allotted for removal with approval of the subdivision and five of the trees will be relocated on the project site. The addendum was prepared to address impacts related to the additional 11 protected oak trees proposed for removal not analyzed under the adopted EIR.

- d) Pursuant to Section 15162 of the CEQA Guidelines, there is no new information of substantial importance that was not known at the time the EIR. Staff has received new information regarding the specific development of Lot E18 (the Taylor property) i.e. development plans and reports. An addendum has been prepared to address impacts related to the additional 11 protected oak trees proposed for removal which were not analyzed under the adopted EIR (94-005). County staff does not find this new information to be of substantial importance.

6. **FINDING:** **SENIOR UNIT** – The subject project meets the regulations, standards and circumstances for a senior unit in accordance with the applicable goals, policies, and regulations of the applicable area plan and zoning codes.

- EVIDENCE:**
- a) That the establishment of the senior unit will not, under the circumstances of the particular application, be detrimental to the health, safety, peace, morals, comfort and general welfare of persons residing or working in the neighborhood or to the general welfare of the County. (*Finding 3*)
- b) All zoning violation abatement costs, if any, have been paid. (*Finding 4*)
- c) The subject property upon which the senior unit is to be built is in compliance with all rules and regulations pertaining to zoning uses, subdivisions and any other applicable provisions of this Title. The proposed senior unit is 840 square feet with an attached approximately 253 square-foot covered terrace which complies with the maximum square footage limitation on senior units of 850 square feet. The proposed height of the unit is 11 feet from average natural grade which is under the maximum height limitation of 35 feet for habitable accessory structures within the Rural Grazing Zoning District or "RG". A senior citizen unit deed restriction has been incorporated into the project as condition of approval 11.
- d) That adequate sewage disposal and water supply facilities exist or are readily available, as approved by the Director of Environmental Health. The Environmental Health Division reviews development proposals within the County to ensure that adequate sewage disposal and water supply facilities exist for the project or are readily available. Environmental Health deemed the project complete on December 8, 2008 with one recommended standard condition of approval, which has been incorporated into the project as condition number 20 which requires a licensed engineer to submit a septic system design for the project to the Environmental Division for review and approval prior to the issuance of permits. The Environmental Health Division has determined that the project, as conditioned will have adequate waste water and water supply facilities.
- e) That the proposed senior unit will not adversely impact traffic conditions in the area. The Public Works Department reviews

development proposals within the County to ensure that traffic conditions would not be adversely affected by the proposal and, if so, they recommend conditions of approval and or mitigation measures to reduce or eliminate potential adverse impacts. The Public Works Department deemed the project complete on December 1, 2008 and recommended three conditions of approval, which have been incorporated into the project as conditions of approval 17 through 19 which require traffic mitigation fees to be paid. The Public Works Department has determined that the project, as conditioned not adversely impact traffic conditions in the area.

- f) The application, plans and supporting materials submitted by the project applicant to the Monterey County Planning Department for the proposed development are found in Project File PLN080350.

7. **FINDING:** **TREE REMOVAL – INLAND** The tree removal is the minimum required under the circumstances and the removal will not involve a risk of adverse environmental impacts.

- EVIDENCE:** a) The project includes application for the removal of 28 oak trees of a protected status, 12 of which were approved for removal with the approval of the Potrero Subdivision and five of which are suitable for re-location on site. A total of 11 protected oak trees are proposed for removal for the project which requires a Use Permit in accordance with Section 21.64.260.D.3.a of Title 21. Staff has found the project consistent with the regulations of Section 21.64.260 of the Monterey County Zoning Ordinance (Title 21) the authority to grant said permit has been met.
- b) On February 6, 1996 the Board of Supervisors (BOS) Resolution Number 96-059 certified the final Environmental Impact Report (EIR Number 94-005) for the Santa Lucia Preserve. A component of the EIR examined a “worse case” scenario regarding complete tree removal for each building envelope or “homeland boundary”. A supplemental EIR (SEIR) to EIR Number 94-005 was prepared and certified for the Potrero Subdivision in 2003. Condition of approval Number 25 of the Potrero Subdivision provided specific tree removal estimates for each lot. The project site was allotted 12 protected trees for removal. The project proposes to remove 11 additional trees with five trees which are suitable for relocation being moved to another location on site. While this project proposes to exceed the allotment for the lot by 11 trees, the environmental effects of total tree removal within the designated building envelopes have been addressed by the Santa Lucia Preserve EIR. Applicable mitigation measures from the EIR have been incorporated as conditions of approval and include a 3 to 1 replacement ratio for protected trees that are not considered “landmark” and a 5 to 1 ratio for landmark trees.
- c) A total of 40 protected oak trees were originally proposed for removal for the Taylor project. Of the 40 trees, 12 were allotted for removal through approval of the Potrero Subdivision and 3 of the trees are considered “Landmark”. County staff requested a supplemental arborist report be prepared to address other options to reduce tree removal to the minimum required under the circumstance of the case. The

supplemental arborist report prepared by Maureen Hamb, dated March 9, 2009 addressed concerns relayed by County staff.

Some of the options included:

- 1) Relocating the proposed pool;
- 2) Eliminating walkways, reducing grading, related garden walls and terracing;
- 3) Relocating the house slightly to the east of the property;
- 4) Eliminating the courtyard proposed in the center of the residence and;
- 5) Removing a kitchen pop-out to preserve trees 33 and 34.

Staff concerns were addressed in the referenced supplemental arborist report as follows:

- a) The relocation of the pool would impact trees 95 and 96 which are healthy and maintain good structure;
- b) Trees 93 and 94 are being removed due to a covered terrace area and are to be professionally relocated, tree 46 which appeared to be proposed for removal due to a walkway can not be saved due to dramatic elevation differences;
- c) The arborist analyzed the potential to reduce tree removal by relocating the house to the east and determined it would increase tree removal;
- d) The trees in the courtyard are in poor condition with areas of decay within structure of the trees and can not be professionally re-located;
- e) According to the arborist and architect, removing the kitchen pop-out to preserve trees 33 and 34 would not leave sufficient space for the preservation of the referenced trees.
Approximately 6 feet by 60 feet (360 square feet) of the south-west wing of the residence would have to be eliminated requiring complete re-design of the interior of the residence (according to the architect) and possibly result additional tree removal. Tree 34 is a 13.4" diameter coast live oak in poor condition; tree 33 is a 25.5" diameter coast live oak in good condition according to a survey conducted by Maureen Hamb.

Project changes have been made since the original submittal which has reduced the tree removal from 39 protected oak trees to a total of 28 protected oaks, 12 which were allotted for removal with the approval of the subdivision and 5 of the trees being relocated on the project site resulting in a total loss of 11 oak trees on the project site.

- d) A Construction Impact Analysis and supplemental report was prepared by Maureen Hamb-WCISA Certified Arborist #2280.
- e) Measures for tree protection during construction have been incorporated as conditions and include tree protection zones and trunk protection (Condition 14).
- f) The removal will not involve a risk of adverse environmental impacts. A supplemental EIR (SEIR) to EIR Number 94-005 was prepared and certified for the Potrero Subdivision in 2003. Condition of approval Number 25 of the Potrero Subdivision provided specific tree removal estimates for each lot. The project site was allotted 12 protected trees for removal. The project proposes to remove 11 additional trees with

five trees which are suitable for relocation being moved to another location on site. While this project proposes to exceed the allotment for the lot by 11 trees, the environmental effects of total tree removal within the designated building envelopes have been addressed by the Santa Lucia Preserve EIR. Applicable mitigation measures from the EIR have been incorporated as conditions of approval and include a 3 to 1 replacement ratio for protected trees that are not considered "landmark" and a 5 to 1 ratio for landmark trees.

- g) Staff conducted a site inspection on August 1, 2008 and June 19, 2009 to verify that the tree removal is the minimum necessary for the project and to identify any potential adverse environmental impacts related to the proposed tree removal.
- h) The application, plans and supporting materials submitted by the project applicant to the Monterey County Planning Department for the proposed development are found in Project File PLN080350.

8. **FINDING:** **APPEALABILITY** - The decision on this project may be appealed to the Board of Supervisors.

EVIDENCE: a) Section 21.80.040.D of the Monterey County Zoning Ordinance states, "The Board of Supervisors is the Appeal Authority to consider appeals from the discretionary decisions, except the decisions made pursuant to subsections A & B of section 21.80.040, of the Planning Commission made pursuant to this title."

DECISION

NOW, THEREFORE, based on the above findings and evidence, the Planning Commission does hereby:

- A. Consider the Addendum to the Environmental Impact Report for the Santa Lucia Preserve (EIR 94-005);
- B. Approve the Combined Development Permit consisting of: 1) An Administrative Permit and Design Approval to allow the construction of a 6,230 square-foot two-story single family dwelling with an attached 1,000 square-foot three-car garage, a 1,055 square-foot barn, an 800 square-foot swimming pool, 15 garden walls totaling 580 linear feet; 2) A Use Permit to allow the removal of 28 oak trees; and 3) An Administrative Permit to allow the construction of an 840 square-foot detached senior citizen unit with a 253 square-foot covered terrace and grading consisting of 240 cubic yards of cut and 75 cubic yards of fill, in general conformance with the attached sketch (**Exhibit 2**) and subject to the conditions (**Exhibit 1**), both exhibits being attached hereto and incorporated herein by reference.

PASSED AND ADOPTED this 26th day of August, 2009 upon motion of Commissioner Diehl, seconded by Commissioner Rochester, by the following vote:

AYES: Brown, Isakson, Salazar, Vandever, Sanchez, Diehl, Rochester, Ottone
NOES: None
ABSENT: Pessagno, Padilla
ABSTAIN: None



Carl Holm, Planning Commission Secretary

COPY OF THIS DECISION MAILED TO APPLICANT ON SEP 11 2009

THIS APPLICATION IS APPEALABLE TO THE BOARD OF SUPERVISORS.

IF ANYONE WISHES TO APPEAL THIS DECISION, AN APPEAL FORM MUST BE COMPLETED AND SUBMITTED TO THE SECRETARY OF THE PLANNING COMMISSION ALONG WITH THE APPROPRIATE FILING FEE ON OR BEFORE

SEP 21 2009

This decision, if this is the final administrative decision, is subject to judicial review pursuant to California Code of Civil Procedure Sections 1094.5 and 1094.6. Any Petition for Writ of Mandate must be filed with the Court no later than the 90th day following the date on which this decision becomes final.

NOTES

1. You will need a building permit and must comply with the Monterey County Building Ordinance in every respect.

Additionally, the Zoning Ordinance provides that no building permit shall be issued, nor any use conducted, otherwise than in accordance with the conditions and terms of the permit granted or until ten days after the mailing of notice of the granting of the permit by the appropriate authority, or after granting of the permit by the Board of Supervisors in the event of appeal.

Do not start any construction or occupy any building until you have obtained the necessary permits and use clearances from the Monterey County Planning Department and Building Services Department office in Salinas.

2. This permit expires 4 years after the above date of granting thereof unless construction or use is started within this period.

**RESOLUTION 09040 -
Monterey County Resource Management Agency
Planning Department
Condition Compliance and/or Mitigation Monitoring
Reporting Plan**

Project Name: Taylor APNs: 239-102-021-000
 File No: PLN080350 Date: _____
 Approved by: Planning Commission

**Monitoring or Reporting refers to projects with an EIR or adopted Mitigated Negative Declaration per Section 21081.6 of the Public Resources Code.*

Permit Code Number	Mitig. Number	Conditions of Approval and/or Mitigation Measures and Responsible Land Use Department	Compliance or Monitoring/Checks to be performed. (Where applicable a certified professional is required for action to be accepted)	Responsible Party for Compliance	Timing	Verification of Compliance (Attache/Date)
RMA - Planning Department						
1.		<p>PD001 - SPECIFIC USES ONLY This Combined Development Permit (PLN080350) allows: 1) An Administrative Permit and Design Approval to allow the construction of a 6,230 square-foot two-story single family dwelling with an attached 1,000 square-foot three-car garage, a 1,055 square-foot barn, an 800 square-foot swimming pool, 15 garden walls totaling 580 linear feet; 2) A Use Permit to allow the removal of 28 Oak trees; and 3) An Administrative Permit to allow the construction of an 840 square-foot detached senior citizen unit with a 253 square-foot covered terrace and grading consisting of 240 cubic yards of cut and 75 cubic yards of fill. The property is located at 8 Goodrich Trail, Carmel (Assessor's Parcel Number 239-102-021-000), Carmel Valley Master Plan. This permit was approved in accordance with County ordinances and land use regulations subject to the following terms and conditions. Any use or construction not in substantial conformance with the terms and conditions of this permit is a violation of County regulations and may result in modification or revocation of this permit and subsequent legal action. No use or construction other than that specified by this permit is</p>	<p>Adhere to conditions and uses specified in the permit.</p> <p>Neither the uses nor the construction allowed by this permit shall commence unless and until all of the conditions of this permit are met to the satisfaction of the Director of the RMA - Planning Department.</p> <p>To the extent that the County has delegated any condition compliance or mitigation monitoring to the Monterey County Water Resources Agency, the Water Resources Agency shall provide all information requested by the County and the County shall bear ultimate responsibility to ensure that conditions and mitigation measures are properly fulfilled.</p>	<p>Owner/ Applicant</p> <p>RMA - Planning</p> <p>WRA RMA - Planning</p>	<p>Ongoing unless otherwise stated</p>	

Permit Cont. Number	Mitig. Number	Conditions of Approval and/or Mitigation Measures and Responsible Land Use Department	Compliance or Monitoring Actions to be performed where applicable to certified professionals is required for action to be accepted	Responsible Party for Compliance	Timing	Verification of Compliance (date/rate)
		allowed unless additional permits are approved by the appropriate authorities. (RMA-Planning Department)				
2.		<p>PD002 - NOTICE-PERMIT APPROVAL</p> <p>The applicant shall record a notice which states: "A Combined Development Permit (Resolution 09040) was approved by the Planning Commission for Assessor's Parcel Number 239-102-021-000 on August 26, 2009. The Combined Development Permit was granted subject to 29 conditions of approval which run with the land. A copy of the permit is on file with the Monterey County RMA - Planning Department." Proof of recordation of this notice shall be furnished to the Director of the RMA - Planning Department prior to issuance of building permits or commencement of the use. (RMA - Planning Department)</p>	Proof of recordation of this notice shall be furnished to the RMA - Planning Department.	Owner/Applicant	Prior to the issuance of grading and building permits or commencement of use.	
3.		<p>PD003(A) - CULTURAL RESOURCES - NEGATIVE ARCHAEOLOGICAL REPORT</p> <p>If, during the course of construction, cultural, archaeological, historical or paleontological resources are uncovered at the site (surface or subsurface resources) work shall be halted immediately within 50 meters (165 feet) of the find until a qualified professional archaeologist can evaluate it. The Monterey County RMA - Planning Department and a qualified archaeologist (i.e., an archaeologist registered with the Society of Professional Archaeologists) shall be immediately contacted by the responsible individual present on-site. When contacted, the project planner and the archaeologist shall immediately visit the site to determine the extent of the resources and to develop proper mitigation measures</p>	Stop work within 50 meters (115 feet) of uncovered resource and contact the Monterey County RMA - Planning Department and a qualified archaeologist immediately if cultural, archaeological, historical or paleontological resources are uncovered. When contacted, the project planner and the archaeologist shall immediately visit the site to determine the extent of the resources and to develop proper mitigation measures required for the discovery.	Owner/Applicant	Ongoing	

Exhibit C

Permit Cond. Number	Mitig. Number	Conditions of Approval and/or Mitigation Measures and Responsible Land Use Department	Compliance or Monitoring Actions to be performed, where applicable, or certified professionals required for action to be accepted	Responsible Party for Compliance	Timing	Verification of Compliance (Time/date)
		required for the discovery. (RMA - Planning Department)				
4.		PD032(A) - PERMIT EXPIRATION The permit shall be granted for a time period of 4 years, to expire on August 12, 2013 unless use of the property or actual construction has begun within this period. (RMA - Planning Department)	The applicant shall obtain a valid grading or building permit and/or commence the authorized use to the satisfaction of the Director of Planning. Any request for extension must be received by the Planning Department at least 30 days prior to the expiration date.	Owner/ Applicant	As stated in the conditions of approval	
5.		PD004 - INDEMNIFICATION AGREEMENT The property owner agrees as a condition and in consideration of the approval of this discretionary development permit that it will, pursuant to agreement and/or statutory provisions as applicable, including but not limited to Government Code Section 66474.9, defend, indemnify and hold harmless the County of Monterey or its agents, officers and employees from any claim, action or proceeding against the County or its agents, officers or employees to attack, set aside, void or annul this approval, which action is brought within the time period provided for under law, including but not limited to, Government Code Section 66499.37, as applicable. The property owner will reimburse the county for any court costs and attorney's fees which the County may be required by a court to pay as a result of such action. County may, at its sole discretion, participate in the defense of such action; but such participation shall not relieve applicant of his obligations under this condition. An agreement to this effect shall be recorded upon demand of County Counsel or concurrent with the issuance of building permits, use of the property, filing of the final map, whichever occurs first and as applicable. The County shall promptly notify the property owner of any such claim, action or proceeding	Submit signed and notarized Indemnification Agreement to the Director of RMA - Planning Department for review and signature by the County. Proof of recordation of the Indemnification Agreement, as outlined, shall be submitted to the RMA - Planning Department.	Owner/ Applicant	Upon demand of County Counsel or concurrent with the issuance of building permits.	

Permit Cond. Number	Mitig. Number	Conditions of Approval and/or Mitigation Measures and Responsible Local Use Department	Compliance or Monitoring Actions to be performed. Where applicable, a certified professional is required for action to be accepted.	Responsible Party for Compliance	Mitigations	Verification of Compliance (date/dates)
		and the County shall cooperate fully in the defense thereof. If the County fails to promptly notify the property owner of any such claim, action or proceeding or fails to cooperate fully in the defense thereof, the property owner shall not thereafter be responsible to defend, indemnify or hold the county harmless. (RMA - Planning Department)				
6.		PD007 - GRADING-WINTER RESTRICTION. No land clearing or grading shall occur on the subject parcel between October 15 and April 15 unless authorized by the Director of RMA - Building Services Department. (RMA - Planning Department and Building Services Department)	Obtain authorization from the Director of RMA - Building Services Department to conduct land clearing or grading between October 15 and April 15.	Owner/ Applicant	Ongoing	
7.		PD009 - GEOTECHNICAL CERTIFICATION. Prior to final inspection, the geotechnical consultant shall provide certification that all development has been constructed in accordance with the geotechnical report. (RMA - Planning Department and Building Services Department)	Submit certification by the geotechnical consultant to the RMA - Building Services Department showing project's compliance with the geotechnical report.	Owner/ Applicant/ Geotechnical Consultant	Prior to final inspection	
8.		PDSP001 - LANDSCAPE PLAN AND MAINTENANCE - SANTA LUCIA PRESERVE (NON-STANDARD) The site shall be landscaped. At least three (3) weeks prior to occupancy, three (3) copies of a landscaping plan shall be submitted to the Director of the RMA - Planning Department. A landscape plan review fee is required for	Submit landscape plans and contractor's estimate to the RMA - Planning Department for review and approval. Landscaping plans shall include the recommendations from the Forest Management Plan or Biological Survey as applicable.	Owner/ Applicant/ Licensed Landscape Contractor/ Licensed Landscape Architect	Prior to issuance of Building Permits	

Permit Condition Number	Mitigation Number	Conditions of Approval and/or Mitigation Measures and Responsible Land Use Department	Compliance or Monitoring Actions to be performed. Where applicable, a certified professional is required for action to be accepted.	Responsible Party for Compliance	Timing	Verification of Compliance (Name/Date)
		<p>this project. Fees shall be paid at the time of landscape plan submittal.</p> <p>Before occupancy, landscaping shall be either installed or a certificate of deposit or other form of surety made payable to Monterey County for that cost estimate shall be submitted to the Monterey County RMA - Planning Department.</p> <p>The landscaping plan shall be in sufficient detail to identify the location, species, and size of the proposed landscaping materials and shall include an irrigation plan. The plan shall be accompanied by a nursery or contractor's estimate of the cost of installation of the plan and shall implement the following:</p> <ol style="list-style-type: none"> 1. Spread of Invasive Species: Implement the provisions of the Resource Management Plan for the San Carlos Ranch (1994) which specify that non-native species known to be invasive shall not be used in landscaping, that invasive exotics shall be controlled by revegetation of disturbed areas with native plants, that the use of landscape species known to be invasive shall be prohibited, and that species such as French broom and pampas grass shall be actively eradicated. 2. Landscape Irrigation: Selection of landscape species shall emphasize species not requiring irrigation such as drought-tolerant native species from local sources, or drought-tolerant non-natives that are known to be non-invasive. If irrigation systems are installed, they shall be designed to minimize runoff of irrigation water into adjacent areas of native vegetation. 3. Fertilizer and Pesticide Application: In the design of landscaping, emphasis shall be placed on the use of species not requiring herbicides, pesticides, or fertilizers. <p style="text-align: right;">(RMA - Planning Department)</p>	<p>Landscaping shall be either installed or a certificate of deposit or other form of surety made payable to Monterey County for that cost estimate shall be submitted to the Monterey County RMA - Planning Department.</p> <p>All landscaped areas and fences shall be continuously maintained by the applicant; all plant material shall be continuously maintained in a litter-free, weed-free, healthy, growing condition.</p>	<p>Owner/ Applicant/ Licensed Landscape Contractor/ Licensed Landscape Architect</p> <p>Owner/ Applicant</p>	<p>Prior to Occupancy</p> <p>Ongoing</p>	

Permit Cont. Number	Mitig. Number	Conditions of Approval and/or Mitigation Measures with Responsible Party/Case Department	Compliance or Monitoring Actions to be performed, where applicable, a certified professional is required for action to be accepted.	Responsible Party for Compliance	Timing	Verification of Compliance (Signature)
9.	<p>PD011(A) – LIGHTING – EXTERIOR LIGHTING PLAN</p> <p>All exterior lighting shall be unobtrusive, down-lit, harmonious with the local area, and constructed or located so that only the intended area is illuminated and off-site glare is fully controlled. The applicant shall submit 3 copies of an exterior lighting plan which shall indicate the location, type, and wattage of all light fixtures and include catalog sheets for each fixture. The lighting shall comply with the requirements of the California Energy Code set forth in California Code of Regulations, Title 24, Part 6. The exterior lighting plan shall be subject to approval by the Director of the RMA - Planning Department, prior to the issuance of building permits. (RMA – Planning Department)</p>	<p>Submit three copies of the lighting plans to the RMA - Planning Department for review and approval. Approved lighting plans shall be incorporated into final building plans.</p>	<p>Owner/ Applicant</p>	<p>Prior to the issuance of building permits.</p>		
10.	<p>PD011 – NOTICE OF REPORT</p> <p>Prior to issuance of building or grading permits, a notice shall be recorded with the Monterey County Recorder which states:</p> <p>“The Following reports have been prepared for the project:</p> <ul style="list-style-type: none"> - “Construction Impacts Analysis” (LIB090351) prepared by Maureen Hamb-WCISA Certified Arborist #2280, Santa Cruz, California, October 1, 2008. - “Subsequent Construction Impacts Analysis” (LIB090350) prepared by Maureen Hamb-WCISA Certified Arborist #2280, Santa Cruz, California, March 9, 2009. - “Geotechnical Engineering Investigation” (LIB090352) prepared by Moore Twining Associates, Inc., Fresno, California, July 11, 2008. <p>All development shall be in accordance with this report.”</p> <p>(RMA – Planning Department)</p>	<p>Proof of recordation of this notice shall be furnished to the RMA - Planning Department.</p>	<p>Owner/ Applicant</p>	<p>Prior to the issuance of grading and building permits</p>		
				<p>Owner/ Applicant</p>	<p>Prior to Occupancy</p>	

Permit Case Number	Mats Number	<i>Conditions of Approval and/or Mitigation Measures and Responsible Land Use Department</i>	<i>Compliance or Monitoring Actions to be performed. Where applicable, a certified professional is required for action to be accepted.</i>	<i>Responsible Party for Compliance</i>	<i>Timing</i>	<i>Verification of Compliance (name/date)</i>
11.		<p>PD20(A) – DEED RESTRICTION – SENIOR CITIZEN UNIT (INLAND)</p> <p>The applicant shall record a deed restriction stating the regulations applicable to a Senior Citizen Unit as follows:</p> <ul style="list-style-type: none"> • An attached senior citizen unit shall not exceed 700 square feet. A detached senior citizen unit shall not exceed 850 square feet. • The senior citizen unit shall not be occupied by more than two persons, one of whom shall be sixty years of age or handicapped. • Not more than one senior citizen unit shall be permitted on any lot or parcel. • The senior citizen unit shall conform with all of the zoning and development standards of the zoning district which governs the lot. • The senior citizen unit shall be designed in such a 	<p>Submit signed and notarized document to the Director of RMA – Planning Department for review and signature by the County.</p>	<p>Owner/ Applicant</p>	<p>Prior to the issuance of grading or building permits</p>	

Permit Cond. Number	Mitig. Number	Conditions of Approval and/or Mitigation Measures and Responsible Parties/Department	Compliance or Monitoring Actions to be performed. Where applicable, a certified professional is required for action to be accepted.	Responsible Party for Compliance	Timing	Verification of Compliance (Time/Date)
		<p>manner as to be visually consistent and compatible with the main residence on site and other residences in the area.</p> <ul style="list-style-type: none"> One usable and accessible parking space shall be provided in addition to the parking required for other uses on site. In areas not served by public sewers, senior citizen units shall not be permitted on lots of less than two acres. Senior citizen units are not permitted on any lot less than ten acres where a guesthouse or caretaker unit already exists. Such units may be converted to a senior citizen unit, subject to an Administrative Permit. Subsequent subdivisions which divide a main residence from the senior citizen unit shall not be permitted except where lots created meet the minimum lot size and density requirements of the existing zoning. (RMA – Planning Department) 	<p>Proof of recordation of the document shall be submitted to the RMA – Planning Department.</p>	<p>Owner/ Applicant</p>	<p>Prior to occupancy or commencement of use</p>	
12.		<p>PD041 – HEIGHT VERIFICATION The applicant shall have a benchmark placed upon the property and identify the benchmark on the building plans. The benchmark shall remain visible onsite until final building inspection. The applicant shall provide evidence from a licensed civil engineer or surveyor, to the Director of the RMA- Building Services Department for review and approval, that the height of the structure(s) from the benchmark is consistent with what was approved on the building permit associated with this project. (RMA – Planning Department and Building Services Department)</p>	<p>The applicant shall have a benchmark placed upon the property and identify the benchmark on the building plans. The benchmark shall remain visible onsite until final building inspection</p> <p>The applicant shall provide evidence from a licensed civil engineer or surveyor, to the Director of the RMA- Building Services Department for review and approval, that the height of the structure(s) from the benchmark is consistent with what was approved on the building permit.</p>	<p>Owner/ Applicant</p>	<p>Prior to the issuance of grading or building permits</p>	
				<p>Owner/ Applicant</p>	<p>Prior to the final inspection</p>	

Permit Condi- Number	Mitig. Number	Conditions of Approval and/or Mitigation Measures and Responsible Party to the Department	Compliance or Monitoring Actions to be performed. Where applicable, a certified professional is required for action to be accepted.	Responsible Party for Compliance	Timing	Verification of Compliance (Timeline)
13.		PD043 – GRADING PERMITS REQUIRED A grading permit is required for new private single family access driveways greater than fifty (50) feet in total length that require 100 cubic yards or more of earthwork. An over the counter (OTC) grading permit may be issued for new private single family access driveways greater than fifty (50) feet in total length that require less than 100 cubic yards of earthwork. (RMA – Planning Department and Building Services Department)	If applicable, apply and receive the appropriate grading permit from Monterey County RMA – Building Services Department	Owner/ Applicant/ Engineer	Prior to the issuance of grading or building permits	
14.		PDSP002 – TREE AND ROOT PROTECTION – SANTA LUCIA PRESERVE (NON-STANDARD) Tree and root protection shall include the implementation of the “Rancho San Carlos Forest Management Plan prepared by Ralph Osterling Consultants, Inc., San Mateo, February 18, 1984 and the “Construction Impact Analysis” prepared for this parcel by Maureen Hamb-WCISA Certified Arborist #2280 dated October 1, 2008 (Library No. LIB090351). Trees which are located close to the construction site shall be protected from inadvertent damage from construction equipment by fencing off the canopy driplines and/or critical root zones (whichever is greater) with protective materials, wrapping trunks with protective materials, avoiding fill of any type against the base of the trunks and avoiding an increase in soil depth at the feeding zone or drip-line of the retained trees. Said protection, approved by the project certified arborist, shall be demonstrated prior to issuance of building permits subject to the approval of the RMA-Director of Planning. If there is any potential for damage, all work must stop in the area and a report, with mitigation measures, shall be submitted by the certified arborist. Should any additional trees not included in this report be harmed, during grading or construction activities, in such a way where removal is required, the owner/applicant shall obtain required permits. (Santa Lucia Preserve EIR MM 32)	Submit evidence of tree protection to the RMA- Planning Department for review and approval. Submit on-going evidence that tree protection measures are in place through out grading and construction phases. If damage is possible, submit an interim report prepared by a certified arborist. Submit photographs of the trees on the property to the RMA – Planning Department after construction to document that the tree protection has been successful or if follow-up remediation or additional permits are required.	Owner/ Applicant	Prior to the issuance of grading or building permits During Construction	

Exhibit C

Permit Conti Number	Mitig. Number	Conditions of Approval and/or Mitigation Measures and Responsible Land Use Department	Compliance or Monitoring Actions to be performed. Where applicable, a certified professional is required for action to be accepted.	Responsible Party for Compliance	Timing	Verification of Compliance (Name/Date)
		(RMA - Planning Department)				
15.		PD035 - UTILITIES - UNDERGROUND All new utility and distribution lines shall be placed underground. (RMA - Planning Department; Public Works)	Install and maintain utility and distribution lines underground.	Owner/ Applicant	Ongoing	
16.		PDSP003 - TREE REPLACEMENT - SANTA LUCIA PRESERVE (NON-STANDARD) The applicant shall plant 77 coast live oak trees. All non- landmark oak trees removed as a result of the project (19 trees) shall be replaced at a 3:1 ratio and all landmark trees (4 trees) at a 5:1 ratio. All oak trees removed shall be replaced in on-site areas suitable for supporting oak species as determined by a qualified resource ecologist. The minimum replacement size shall be 5 gallons. Nursery and/or field propagation of oak seedlings and/or saplings shall be initiated prior to the onset of the particular development phase that results in the loss of oak trees. The reforestation program shall include a monitoring element that guarantees a success period of not less than 5 years after planting and a success ratio threshold of no less than 90%. At five years, a report shall be prepared by a registered forester or arborist and submitted to the Planning Department for review and approval of the Director of Planning describing reforestation activities conducted during the year and shall describe success rates and corrective measures provided to adjust program based on earlier successes or failures. This condition shall cease once the required number of replacement trees for a particular phase have passed the	The applicant shall submit photographic evidence to the Director of the RMA- Planning Department demonstrating that required replacement trees have been planted. The applicant shall provide evidence after five years that tree planting has been successful. The property owner must enter into a contractual agreement with a certified arborist from Monterey County's list of approved arborist consultants. The agreement must require monitoring by an arborist (from the County's list of approved arborist consultants) to ensure a success period of the referenced replacement trees for a minimum of 5 years.	Owner/ Applicant Owner/ Applicant Owner/ Applicant	Prior to final inspection 5 years after successful tree planting For a minimum of 5 years.	

Permit Cont. Number	Mitig. Number	Conditions of Approval and/or Mitigation Measures and Responsible Land Use Department	Compliance or Monitoring Actions to be performed. Where applicable, a certified professional is required for action to be accepted.	Responsible Party for Compliance	Timing	Verification of Compliance (Date/Time)
		<p>five-year anniversary completion date required for plan success. The property owner must enter into a contractual agreement with a certified arborist from Monterey County's list of approved arborist consultants. The agreement must require monitoring by an arborist (from the County's list of approved arborist consultants) to ensure a success period of the referenced replacement trees for a minimum of 5 years. (Santa Lucia Preserve EIR MM 27 and 36) (RMA - Planning Department)</p>				
RMA - Public Works Department						
17.		<p>PW0043 - REGIONAL DEVELOPMENT IMPACT FEE Prior to issuance of building permits, applicant shall pay the Regional Development Impact Fee (RDIF) pursuant to Monterey Code Chapter 12.90. The fee amount shall be determined based on the parameters adopted in the current</p>	<p>Applicant shall pay Monterey County Building Services Department the traffic mitigation fee.</p>	Owner/ Applicant	Prior to the issuance of building permits.	
18.		<p>PW0006 - CARMEL VALLEY The Applicant shall pay the Carmel Valley Master Plan Area Traffic Mitigation fee pursuant to the Board of Supervisors Resolution NO. 95-110, adopted September 12, 1995 (Fees are updated annually based on CCI). (Public Works)</p>	<p>Applicant shall pay to the required traffic mitigation fee.</p>	Owner/ Applicant	Prior to Building Permits Issuance	
19.		<p>PW0040 - HIGHWAY 1 SHORT TERM IMPROVEMENTS Applicant shall Contribute \$822.00 (2008 dollars) to County of Monterey as payment of the project's pro rata share at the cost of short-term operational improvements to State Highway One. (Public Works)</p>	<p>Applicant shall pay the required Traffic Mitigation Fee.</p>	Owner/ Applicant	Prior to Issuance of Building Permits	

Exhibit C

Permit Cond. Number	Mitig. Number	Conditions of Approval and/or Mitigation Measures and Responsible Party (Use Department)	Compliance or Monitoring Actions to be performed. Where applicable, a certified professional is required for action to be accepted.	Responsible Party for Compliance	Timing	Verification of Compliance (Timeline)
Health Department Environmental Health Division						
20.		EH11 - SEPTIC SYSTEM DESIGN Submit plans for review and approval showing the location and design of the proposed septic system meeting the standards found in Chapter 15.20 of the Monterey County Code (Septic Ordinance) and "Prohibitions", Central Coast Basin Plan, RWQCB. (Environmental Health)	Division of Environmental Health must approve plans. Applicant shall obtain a permit to install the septic system.	CA Licensed Engineer /Owner/ Applicant	Prior to filing the final parcel map or issuance of building	
Monterey County Water Resources Agency						
21.		WR40 - WATER CONSERVATION MEASURES The applicant shall comply with Ordinance No. 3932, or as subsequently amended, of the Monterey County Water Resources Agency pertaining to mandatory water conservation regulations. The regulations for new construction require, but are not limited to: a. All toilets shall be ultra-low flush toilets with a maximum tank size or flush capacity of 1.6 gallons, all shower heads shall have a maximum flow capacity of 2.5 gallons per minute, and all hot water faucets that have more than ten feet of pipe between the faucet and the hot water heater serving such faucet shall be equipped with a hot water recirculating system. b. Landscape plans shall apply xeriscape principles, including such techniques and materials as native or low water use plants and low precipitation sprinkler heads, bubblers, drip irrigation systems and timing devices. (Water Resources Agency)	Compliance to be verified by building inspector at final inspection.	Owner/ Applicant	Prior to final building inspect- ion/ occupancy	

Exhibit C

Permit Cond. Number	Mitig. Number	Conditions of Approval and/or Mitigation Measures and Responsible Land Use Department	Compliance or Monitoring Actions (to be performed. Where applicable a certified professional is required for action to be accepted)	Responsible Party for Compliance	Filing	Verification of Compliance (name/date)
22.		WRSP001 - DRAINAGE PLAN (NON-STANDARD) Prior to issuance of any grading and/or building permits a drainage plan shall be prepared by a registered civil engineer or architect addressing on-site and off-site impacts. Impervious surface stormwater runoff shall be directed to the existing detention ponds for the Santa Lucia Preserve Subdivision. Drainage improvements shall be constructed in accordance with plans approved by the Water Resources Agency. (Water Resources Agency)	Submit 3 copies of the engineered drainage plan to the Water Resources Agency for review and approval.	Owner/ Applicant/ Engineer	Prior to issuance of any grading or building permits	
Fire Agency (Carmel Valley Fire Protection District)						
23.		FIRE007 - DRIVEWAYS Driveways shall not be less than 12 feet wide unobstructed, with an unobstructed vertical clearance of not less than 15 feet. The grade for all driveways shall not exceed 15 percent. Where the grade exceeds 8 percent, a minimum structural roadway surface of 0.17 feet of asphaltic concrete on 0.34 feet of aggregate base shall be required. The driveway surface shall be capable of supporting the imposed load of fire apparatus (22 tons), and be accessible by conventional-drive vehicles, including sedans. For driveways with turns 90 degrees and less, the minimum horizontal inside radius of curvature shall be 25 feet. For driveways with turns greater than 90 degrees, the minimum horizontal inside radius curvature shall be 28 feet. For all driveway turns, an additional surface of 4 feet shall be added. All	Applicant shall incorporate specification into design and enumerate as "Fire Dept. Notes" on plans.	Applicant or owner	Prior to issuance of grading and/or building permit.	

Exhibit C

Permit (Cont. Number	Mitig. Number	Conditions of Approval/Other Mitigation Measures and Responsible Party (See Department)	Compliance or Monitoring Actions to be performed. Where applicable, to certified professionals required for action to be accepted.	Responsible Party for Compliance	Timing	Verification of Compliance (Timeline)
		<p>driveways exceeding 150 feet in length, but less than 800 feet in length, shall provide a turnout near the midpoint of the driveway. Where the driveway exceeds 800 feet, turnouts shall be provided at no greater than 400-foot intervals. Turnouts shall be a minimum of 12 feet wide and 30 feet long with a minimum of 25-foot taper at both ends. Turnarounds shall be required on driveways in excess of 150 feet of surface length and shall long with a minimum 25-foot taper at both ends. Turnarounds shall be required on driveways in excess of 150 feet of surface length and shall be located within 50 feet of the primary building. The minimum turning radius for a turnaround shall be 40 feet from the center line of the driveway. If a hammerhead/T is used, the top of the "T" shall be a minimum of 60 feet in length. (Carmel Valley Fire Protection District).</p>	<p>Applicant shall schedule fire dept. clearance inspection</p>	<p>Applicant or owner</p>	<p>Prior to final building inspection.</p>	
24.	<p>FIRE008 - GATES All gates providing access from a road to a driveway shall be located at least 30 feet from the roadway and shall open to allow a vehicle to stop without obstructing traffic on the road. Gate entrances shall be at least the width of the traffic lane but in no case less than 12 feet wide. Where a one-way road with a single traffic lane provides access to a gated entrance, a 40-foot turning radius shall be used. Where gates are to be locked, the installation of a key box or other acceptable means for immediate access by emergency equipment may be required. (Carmel Valley Fire Protection District)</p>	<p>Applicant shall incorporate specification into design and enumerate as "Fire Dept. Notes" on plans</p>	<p>Applicant or owner</p>	<p>Prior to issuance of grading and/or building permit.</p>		
			<p>Applicant shall schedule fire dept. clearance inspection</p>	<p>Applicant or owner</p>	<p>Prior to final building inspection.</p>	

Exhibit C

Permit Code Number	Wing Number	Conditions of Approval on Mitigation Measures and Responsible Land Use Department	Compliance or Monitoring Actions to be performed. Where applicable, a certified professional is required for action to be accepted.	Responsible Party for Compliance	Timing	Verification of Compliance (date/dates)
25.		FIRE019 - DEFENSIBLE SPACE REQUIREMENTS - (STANDARD) Manage combustible vegetation within a minimum of 100 feet of structures (or to the property line). Limb trees 6 feet up from ground. Remove limbs within 10 feet of chimneys. Additional and/or alternate fire protection or firebreaks approved by the fire authority may be required to provide reasonable fire safety. Environmentally sensitive areas may require alternative fire protection, to be determined by Reviewing Authority and the Director of Planning and Building Inspection. (Carmel Valley Fire Protection District)	Applicant shall incorporate specification into design and enumerate as "Fire Dept. Notes" on plans. Applicant shall schedule fire dept. clearance inspection	Applicant or owner Applicant or owner	Prior to issuance of grading and/or building permit. Prior to final building inspection	
26.		FIRE021 - FIRE PROTECTION EQUIPMENT & SYSTEMS - FIRE SPRINKLER SYSTEM (STANDARD) All structures shall be fully protected with automatic fire sprinkler system(s). Installation shall be in accordance with the applicable NFPA standard. A minimum of four (4) sets of plans for fire sprinkler systems must be submitted by a California licensed C-11 contractor and approved prior to installation. This requirement is not intended to delay issuance of a building permit. A rough sprinkler inspection must be scheduled by the installing contractor and completed prior to requesting a framing inspection. (Carmel Valley Fire Protection District)	Applicant shall enumerate as "Fire Dept. Notes" on plans. Applicant shall schedule fire dept. rough sprinkler inspection Applicant shall schedule fire dept. final sprinkler inspection	Applicant or owner Applicant or owner Applicant or owner	Prior to issuance of building permit. Prior to framing inspection Prior to final building inspection	
27.		FIRE024 - FIRE ALARM SYSTEM - (SINGLE FAMILY DWELLING) The residence shall be fully protected with an approved household fire warning system as defined by NFPA	Applicant shall enumerate as "Fire Dept. Notes" on plans.	Applicant or owner	Prior to issuance of building permit.	

Exhibit C

Permit Code Number	Mitig. Number	Conditions of Approval/and/or Mitigation Measures and Responsible Land Use Department	Compliance or Monitoring Actions to be performed where applicable to certified professional's required action to be accepted.	Responsible Party for Compliance	Timing	Verification of Compliance (time/date)
		Standard 72. Plans and specifications for the household fire warning system shall be submitted by a California licensed C-10 contractor and approved prior to installation. Household fire warning systems installed in lieu of single-station smoke alarms required by the Uniform Building Code shall be required to be placarded as permanent building equipment. (Carmel Valley Fire Protection District).	Applicant shall submit fire alarm plans and obtain approval. Applicant shall schedule fire alarm system acceptance test.	Applicant or owner	Prior to rough sprinkler or framing inspection Prior to final building inspection	
28.		FIRE028 - ROOF CONSTRUCTION - (CARMEL VALLEY FPD) All new structures, and all existing structures receiving new roofing over 50 percent or more of the existing roof surface within a one-year period, shall require a minimum of ICBO Class A roof construction. Responsible Land Use Department: (Carmel Valley Fire Protection District)	Applicant shall enumerate as "Fire Dept. Notes" on plans.	Applicant or owner	Prior to issuance of building permit.	
29.		FIRE030 - NON-STANDARD- NOTES ON PLANS - (CARMEL VALLEY FPD) Attach all fire conditions as notes on construction plans. (Carmel Valley Fire Protection District)	Applicant shall enumerate as "Fire Dept. Notes" on plans.	Applicant or owner	Prior to issuance of building permit.	

Exhibit C

END OF CONDITIONS

Rev. 07/11/2009

**Addendum Pursuant to the California Environmental Quality
Act ARTICLE 11 Section 15164**

**Taylor
Planning File No. PLN080350
Combined Development Permit**

1. Introduction

This addendum was prepared to quantify the site specific potential environmental impacts of a residential development project within a building envelope "Homeland Boundary" established by the Rancho San Carlos Subdivision. The Santa Lucia Preserve Project (PC94067) is comprised of several entitlements, including the certification of and Environmental Impact Report and a Combined Development Permit. The Combined Development Permit, Resolution No. 96-059, consisted of a Vesting Tentative Subdivision map or the creation of 266 lots and 31 parcels, and Use Permits for tree removal and development on slopes exceeding 30% among other components. The environmental implications of such actions were addressed within the Santa Lucia Final Environmental Impact Report No. 94-005. A Subsequent Environmental Impact Report (SEIR) was prepared for Phase E of the Santa Lucia Preserve Subdivision also known as the "Portrero Subdivision" which was adopted by the Board of Supervisors through Resolution Number 05-046.

The Taylor project consists of a Combined Development Permit consisting of: 1) An Administrative Permit and Design Approval to allow the construction of a 6,230 square-foot two-story single family dwelling with an attached 1,000 square-foot three-car garage, a 1,055 square-foot barn, an 800 square-foot swimming pool, 15 garden walls totaling 580 linear feet; 2) A Use Permit to allow the removal of 11 oak trees and the re-location of 5 oak trees; and 3) An Administrative Permit to allow the construction of an 840 square-foot detached senior citizen unit with a 253 square-foot covered terrace, and grading consisting of 240 cubic yards of cut and 75 cubic yards of fill. The development is proposed on a 35-acre parcel which contains a building envelope or "homeland boundary".

This technical addendum has been prepared pursuant to Article 11, Section 15164 of the California Environmental Quality Act guidelines to make minor technical changes to the project analyzed in the Santa Lucia Preserve Final Environmental Impact Report, certified February 6, 1996, by Board of Supervisors Resolution No. 96-059.

Article 11, Section 15164 provides in pertinent part of the following:

(b) An addendum to an adopted negative declaration may be prepared if only minor technical changes or additions are necessary or none of the conditions described in Section 15162 calling for the preparation of a subsequent EIR or negative declaration have occurred.

(c) An addendum need not be circulated for public review but can be included in or attached to the final EIR or adopted Negative Declaration.

2. Scope and Purpose of this addendum

The purpose of this addendum is to identify minor technical changes and provide clarifications of the site-specific conditions for the proposed residential development. The Combined Development Permit, Resolution No. 96-060, approved the removal of 451 protected trees for building sites and 1,029 protected trees for roads and driveways subject to the recommendations prescribed by the "Rancho San Carlos Forest Management Plan" prepared by Ralph Osterling Consultants, Inc., San Mateo, February 18, 1984. This project proposes to remove 28 protected oak trees, 12 of which were allotted for removal with the approval of the Potrero Subdivision and 5 of which are being relocated on the project site resulting in the requirement of a Use Permit for the removal of 11 protected oak trees. The Environmental Impact Report for the Santa Lucia Preserve analyzed a "worse case" scenario comprised of total removal of protected oaks within building envelopes or "homeland boundaries". The environmental implications of these actions have been addressed by the EIR, which suggested appropriate mitigation measures to avoid significantly adverse environmental impacts. Such mitigation measures have been incorporated into the Taylor Combined Development Permit (PLN080350) as conditions of approval. Condition of Approval number 16, incorporates the requirements from Mitigation Measures 27 and 36 of the Santa Lucia Preserve EIR and requires a tree replacement ratio of 3:1 for protected oak trees and a replacement ratio of 5:1 for landmark oak trees. Condition of Approval number 14, incorporates the requirements from Mitigation Measure number 32 of the Santa Lucia Preserve EIR and requires that specific tree and root protection guidelines are followed.

3. Conclusion

The purpose of this addendum is to identify minor technical changes and provide clarifications of the site-specific conditions and the scope of work for the proposed residential development. Staff has reviewed the Santa Lucia Preserve Environmental Impact Report, Resolution No. 96-060 and the proposed residential development for consistency with the environmental considerations contained within. Staff finds that the site-specific conditions in relation to the proposed Combined Development Permit do not create substantial changes and therefore do not warrant the preparation of a subsequent environmental document.



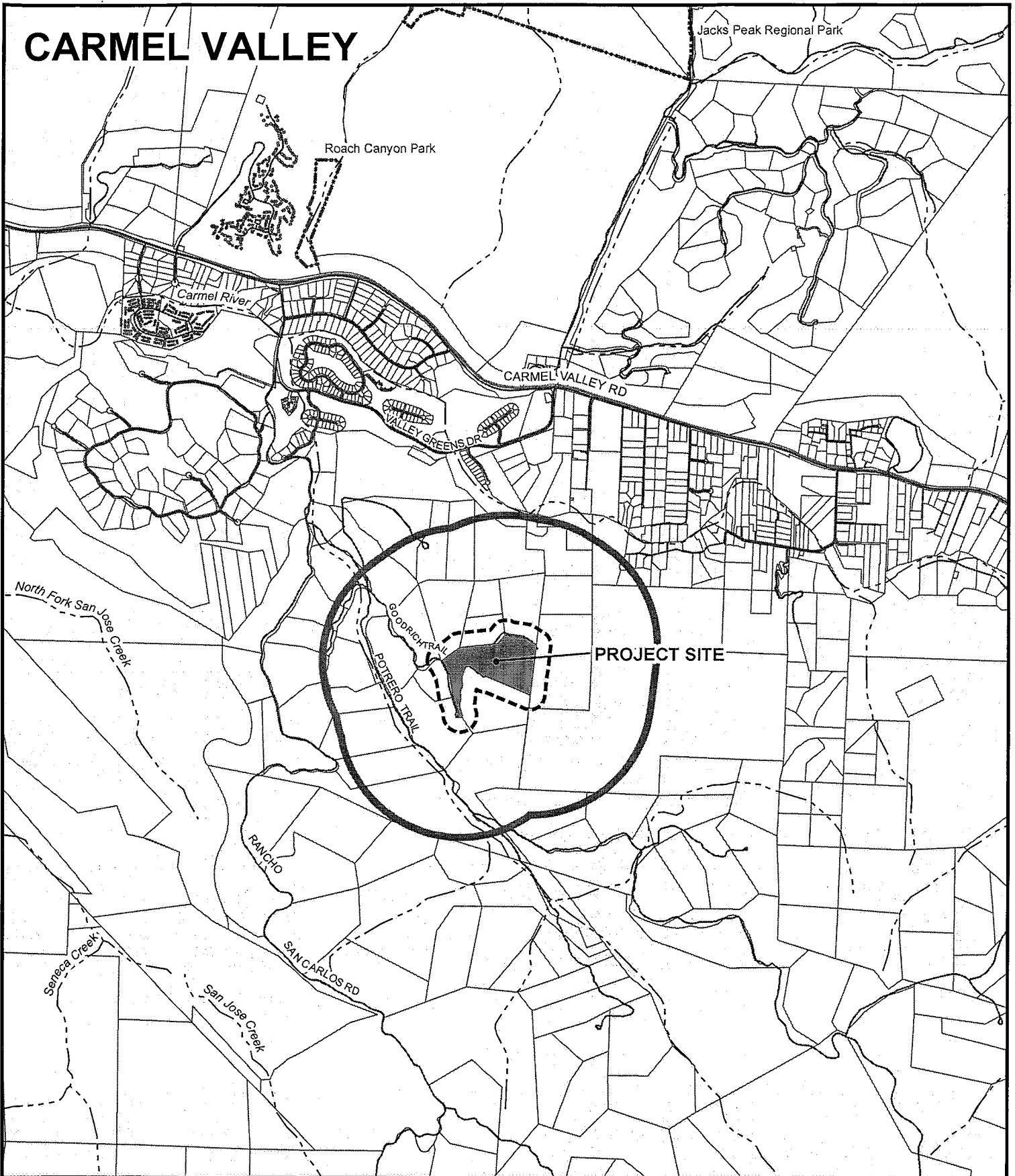

CARMEL VALLEY



APPLICANT: ATTORNEYS BENEFITS CORPORATION

APN: 239-102-021-000

FILE # PLN130509

 2500' Limit  300' Limit  Water  City Limits

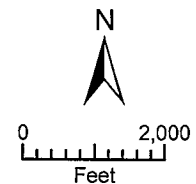

PLANNER: LOPEZ

Exhibit E