

**MIKE NOVO
ZONING ADMINISTRATOR**

**COUNTY OF MONTEREY
STATE OF CALIFORNIA**

RESOLUTION NO. 050734

A. P. # 008-341-001-000

In the matter of the application of
Walter Jones Family LP (PLN050734)

FINDINGS AND DECISION

to allow a **Combined Development Permit** in accordance with Title 20 (Zoning) Chapter 20.76 (Combined Development Permits) of the Monterey County Code, consisting of a Coastal Administrative Permit for the demolition of an existing 2,788 square foot single family residence and the construction of a new 3,569 square foot single family residence; Coastal Administrative Permit for a new 425 square foot guesthouse and an attached 549 square foot garage; retaining walls to be built on 30 percent slopes, with approximately 310 cu. yds. cut/215 cu. yds. fill; a Variance to exceed the 100' setback from Seventeen Mile Drive and a Variance to exceed the 50' minimum accessory structure setback.. The property is located at 3365 17 Mile Drive, Pebble Beach, Del Monte Forest Area, Coastal Zone and came on regularly for meeting before the Zoning Administrator on May 11, 2006.

Said Zoning Administrator, having considered the application and the evidence presented relating thereto,

FINDINGS OF FACT

1. **FINDING:** **CONSISTENCY** – The Project, as conditioned is consistent with applicable plans and policies, the Del Monte Forest Land Use Plan, Coastal Implementation Plan (Part 5), Part 6 of the Coastal Implementation Plan, and the Monterey County Zoning Ordinance (Title 20) which designates this area as appropriate for residential development.

EVIDENCE: **(a) Plan Conformance** – Staff has reviewed the project as contained in the application and accompanying materials for consistency with the Del Monte Forest Land Use Plan (LUP), Part 5 of the Coastal Implementation Plan (CIP), and Part 6 of the Coastal Implementation Plan (CIP) and for conformity with the Monterey County Zoning Ordinance (Title 20) and has determined that the project is consistent with the Del Monte Forest Land Use Plan, which designates this area as appropriate for residential development. Conditions have been incorporated addressing exterior lighting and landscaping requirements. Staff notes are provided in Project File PLN050734.

(b) Land Use – The parcel is zoned Low Density Residential, 1.5 acres/unit, Design Control District, Coastal Zone (LDR/1.5-D (CZ)). The uses are allowed per §20.14.040.A for a single-family residence. The proposed uses meet all necessary regulations.

(c) Development Standards – The project is in compliance with Site Development Standards for a Low Density Residential District in accordance with §20.14.060. However, one variance and one exception are required. One exception to allow construction of the main structure in the 100' setback from

17 Mile Drive, and a variance to allow construction of an accessory structure in the required 50' setback (see below). The project meets policies 56 and 57 of the Del Monte Forest Land Use Plan through the use of design approved colors to be subordinate to the environment and vegetation and topography to provide screening from public viewing areas (Exhibit E).

(d) Floor Area Ratio (FAR) – Development standards for the zoning district limit FAR to 17.5 percent of the property. The project proposes FAR of 10.4 percent (4,543 square feet).

(e) Site Visit – The on-site inspection of the parcel by the project planner.

(f) Project File – The application, plans, and support materials submitted by the applicant to the Monterey County Planning and Building Inspection Department for the proposed development, found in Project File PLN050734.

2. FINDING: SITE SUITABILITY – The site is suitable for the use proposed.

EVIDENCE: (a) The application and plans submitted by the applicant in the project file at the Monterey County Planning and Building Inspection Department.

(b) The on-site inspection of the parcel by the project planner.

(c) The subject parcel meets the requirements as detailed in “Geotechnical Investigation Residence Replacement Project 3365 17-Mile Drive” by D&M Consulting Engineers, Inc. (15 February 2006).

(d) The project as proposed is consistent with policies of the Del Monte Forest Land Use Plan dealing with development in archaeologically sensitive areas, evidenced by the archaeological report prepared by Basin Research Associates, dated 8 February 2006 contained in the project file. Condition number 3 has been added to require that work be stopped in the event that any archaeological resources are found on site.

(e) The project has been reviewed by the Monterey County Planning and Building Inspection Department, Water Resources Agency, the applicable Fire Department, Public Works Department and Environmental Health Division. There has been no indication from those agencies that the site is not suitable. There are no physical or environmental constraints such as geologic or seismic hazard areas, environmentally sensitive habitats, or similar areas that would indicate the site is not suitable for the use proposed.

(f) The subject property is not adjacent to the sea shore and is not described as an area where the Local Coastal Program requires access, according to Sections 20.70.050.B.4.c.i and ii.

3. FINDING: VARIANCE (Special Circumstances) – Because of special circumstances applicable to the subject property, including the size, shape, topography, location of the lot, or the surrounding area, the strict application of the Monterey County Coastal Implementation Plan would deprive the subject property of privileges enjoyed by other property owners in the vicinity under the identical zoning classification.

EVIDENCE: (a) Due to the triangular nature of the subject parcel, topography (slopes of 30 percent or greater) and existing trees, special circumstances exist that do not allow the applicant to meet this requirement.

(b) The proposed construction will be partially screened by native vegetation and will consist of colors that will help sublimate the project to the surrounding environment.

(c) Site plan submitted by applicant.

4. **FINDING: VARIANCE (Special Privileges)** – The variance to allow construction in the 50' setback will not constitute a grant of privileges inconsistent with the limitations upon other property owners in the vicinity and zone in which such property is situated.

EVIDENCE: (a) Due to the subject parcel's shape, topography (slopes of 30 percent or greater) and existing trees, granting of the requested variances will not constitute a special privilege not enjoyed by other property owners in the vicinity.

(b) PC965288, Catlin

(c) PLN020561, Segel

5. **FINDING: VARIANCE (Authorized Use)** – The variance shall not be granted for a use or activity which is not otherwise expressly authorized by the zone regulation governing the parcel of property.

EVIDENCE: (a) The proposed project is allowed under the zoning classification.

(b) Materials and document in file PLN050734.

6. **FINDING: SLOPE WAIVER** – The request for the proposed development, replacement of existing retaining walls, to be partially located on slopes exceeding 30 percent is consistent with Section 20.147.060.G.1. of the Regulations for Development in the Del Monte Land Use Plan Area since alternative building sites would entail development to occur on slopes equal or greater than 30 percent.

The request for the proposed development to be partially located on slopes exceeding 30 percent is consistent with §20.64.230E.b. of the Del Monte Forest CIP in that the proposed development better achieves the goals, policies and objectives of the Monterey County Local Coastal Program than other development alternatives.

EVIDENCE: (a) Slope analysis map prepared by the Bolton Design Group, which shows all slopes exceeding 30 percent.

(b) Site plan contained in file PLN050734 indicating existing and proposed retaining walls.

7. **FINDING: CEQA** – The proposed project will not have a significant environmental impact.

EVIDENCE: Criteria contained in Article 19, Sections 15300.2 (Exceptions) & 15303 (Small Structures) of the California Environmental Quality Act Guidelines allow this project to be categorically exempted from environmental review. Due to the project's limited scale, no significant adverse environmental impacts were identified during review of the proposed project.

8. **FINDING: HEALTH AND SAFETY** – The establishment, maintenance, and operation of the proposed development will not, under the circumstances of the particular case, be detrimental to the health, safety, peace, morals, comfort,

and general welfare of persons residing or working in the neighborhood or to the general welfare of the County.

EVIDENCE: The project as described in the application and accompanying material was reviewed by the Department of Planning and Building Inspection, applicable Fire Department, Public Works and Parks Departments, Environmental Health Division, and Water Resources Agency. The respective departments and Agency have recommended conditions, where appropriate, to ensure that the project will not have an adverse effect on the health, safety, and welfare of persons either residing or working in the neighborhood or the County in general.

9. FINDING: NO VIOLATIONS – The subject properties are in compliance with all rules and regulations pertaining to zoning uses, subdivisions and other applicable provisions of Title 20. Zoning violation abatement costs, if any, have been paid.

EVIDENCE: Staff verification of the Monterey County Planning and Building Inspection Department records indicates that no violations exist on subject property.

10. FINDING: APPEALABILITY – The project is appealable to the Planning Commission and the California Coastal Commission.

EVIDENCE: (a) Sections 20.86.070 and 20.86.080 of the Monterey County Coastal Implementation Plan.

11. FINDING: EXCEPTION 100' Setback – An exception may be allowed by the decision-making body upon a finding that the new development may be screened from view of travelers on 17 Mile Drive by existing vegetation or terrain.

EVIDENCE: (a) Section 20.147.070.C.9 of the Del Monte Coastal Implementation Plan.
(b) Due to the width limitations of the triangular lot, topography (slopes of 30 percent or greater) and existing trees, the 100' setback requirement cannot be reasonably met.
(c) Site plan contained in file PLN050734.
(d) The proposed construction will be partially screened by native vegetation and will consist of colors that will help sublimate the project to the surrounding environment.

DECISION

It is the decision of the Zoning Administrator of the County of Monterey that said application for a Combined Development Permit be granted as shown on the attached sketch and subject to the attached conditions.

PASSED AND ADOPTED this 11th day of May, 2006.

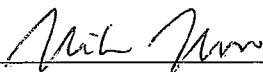

MIKE NOVO, ZONING ADMINISTRATOR

COPY OF THIS DECISION MAILED TO APPLICANT ON

MAY 30 2006

THIS APPLICATION IS APPEALABLE TO THE BOARD OF SUPERVISORS. IF ANYONE WISHES TO APPEAL THIS DECISION, AN APPEAL FORM MUST BE COMPLETED AND SUBMITTED TO THE CLERK OF THE BOARD OF SUPERVISORS ALONG WITH THE APPROPRIATE FILING FEE ON OR BEFORE

JUN - 9 2006

THIS APPLICATION IS ALSO APPEALABLE TO THE COASTAL COMMISSION. UPON RECEIPT OF NOTIFICATION OF THE DECISION BY THE BOARD OF SUPERVISORS, THE COMMISSION ESTABLISHES A 10 WORKING DAY APPEAL PERIOD. AN APPEAL FORM MUST BE FILED WITH THE COASTAL COMMISSION. FOR FURTHER INFORMATION, CONTACT THE COASTAL COMMISSION AT (831) 427-4863 OR AT 725 FRONT STREET, SUITE 300, SANTA CRUZ, CA

This decision, if this is the final administrative decision, is subject to judicial review pursuant to California Code of Civil Procedure Sections 1094.5 and 1094.6. Any Petition for Writ of Mandate must be filed with the Court no later than the 90th day following the date on which this decision becomes final.

NOTES

1. You will need a building permit and must comply with the Monterey County Building Ordinance in every respect.

Additionally, the Zoning Ordinance provides that no building permit shall be issued, nor any use conducted, otherwise than in accordance with the conditions and terms of the permit granted or until ten days after the mailing of notice of the granting of the permit by the appropriate authority, or after granting of the permit by the Board of Supervisors in the event of appeal.

Do not start any construction or occupy any building until you have obtained the necessary permits and use clearances from the Monterey County Planning and Building Inspection Department office in Salinas.

2. This permit expires 2 years after the above date of granting thereof unless construction or use is started within this period.

Monterey County Planning and Building Inspection
Condition Compliance and/or Mitigation Monitoring
Reporting Plan

Project Name: Jones

File No: PLN050734

Approval by: Zoning Administrator

APNs: 008-391-001-000

Date: May 11, 2006

<i>Permit Cond. Number</i>	<i>Mitig. Number</i>	<i>Conditions of Approval and/or Mitigation Measures and Responsible Land Use Department</i>	<i>Compliance or Monitoring Actions to be performed. Where applicable, a certified professional is required for action to be accepted.</i>	<i>Responsible Party for Compliance</i>	<i>Timing</i>	<i>Verification of Compliance (name/date)</i>
1		<p>PBD029 - SPECIFIC USES ONLY This Combined Development Permit (PLN50734) allows for the demolition of an existing 2,788 square foot single-family residence and the construction of a new 3,569 square foot single-family residence; construction of a new 425 square foot guesthouse and an attached 549 square foot garage; retaining walls to be built on 30 percent slopes, with approximately 310 cu. yds. cut/215 cu. yds. fill; an exception to encroach on the 100' setback from 17 Mile Drive and a variance to exceed the 50' minimum accessory structure setback. The property is located at 3365 17 Mile Drive, (Assessor's Parcel Number 008-391-001-000), Pebble Beach. This permit was approved in accordance with County ordinances and land use regulations subject to the following terms and conditions. Neither the uses nor the construction allowed by this permit shall commence unless and until all of the conditions of this permit are met to the satisfaction of the Director of Planning and Building Inspection. Any use or construction not in substantial conformance with the terms and conditions of this permit is a violation of County regulations and may result in modification or revocation of this permit and subsequent legal action. No use or construction other than that specified by this permit is allowed unless additional permits are approved by the appropriate authorities. (Planning and Building Inspection)</p>	Adhere to conditions and uses specified in the permit.	Owner/ Applicant	Ongoing unless other- wise stated	

<i>Permit Cond. Number</i>	<i>Mitig. Number</i>	<i>Conditions of Approval and/or Mitigation Measures and Responsible Land Use Department</i>	<i>Compliance or Monitoring Actions to be performed. Where applicable, a certified professional is required for action to be accepted.</i>	<i>Responsible Party for Compliance</i>	<i>Timing</i>	<i>Verification of Compliance (name/date)</i>
2		<p>PBD025 - NOTICE-PERMIT APPROVAL</p> <p>The applicant shall record a notice which states: A permit (Resolution 050734) was approved by the Zoning Administrator for Assessor's Parcel Number 008-391-001-000 on May 11, 2006. The permit was granted subject to twenty (20) conditions of approval which run with the land. A copy of the permit is on file with the Monterey County Planning and Building Inspection Department." Proof of recordation of this notice shall be furnished to the Director of Planning and Building Inspection prior to issuance of building permits or commencement of the use. (Planning and Building Inspection)</p>	Proof of recordation of this notice shall be furnished to PBI.	Owner/ Applicant	Prior to Issuance of grading and building permits or start of use.	
3		<p>PBD030 - STOP WORK - RESOURCES FOUND</p> <p>If, during the course of construction, cultural, archaeological, historical or paleontological resources are uncovered at the site (surface or subsurface resources) work shall be halted immediately within 50 meters (165 feet) of the find until a qualified professional archaeologist can evaluate it. The Monterey County Planning and Building Inspection Department and a qualified archaeologist (i.e., an archaeologist registered with the Society of Professional Archaeologists) shall be immediately contacted by the responsible individual present on-site. When contacted, the project planner and the archaeologist shall immediately visit the site to determine the extent of the resources and to develop proper mitigation measures required for the discovery. (Planning and Building Inspection)</p>	Stop work within 50 meters (165 feet) of uncovered resource and contact the Monterey County Planning and Building Inspection Department and a qualified archaeologist immediately if cultural, archaeological, historical or paleontological resources are uncovered. When contacted, the project planner and the archaeologist shall immediately visit the site to determine the extent of the resources and to develop proper mitigation measures required for the discovery.	Owner/ Applicant/ Archaeologist	Ongoing	

<i>Permit Cond. Number</i>	<i>Mitig. Number</i>	<i>Conditions of Approval and/or Mitigation Measures and Responsible Land Use Department</i>	<i>Compliance or Monitoring Actions to be performed. Where applicable, a certified professional is required for action to be accepted.</i>	<i>Responsible Party for Compliance</i>	<i>Timing</i>	<i>Verification of Compliance (name/date)</i>
4		<p>WR40 - WATER CONSERVATION MEASURES The applicant shall comply with Ordinance No. 3932, or as subsequently amended, of the Monterey County Water Resources Agency pertaining to mandatory water conservation regulations. The regulations for new construction require, but are not limited to:</p> <p>a. All toilets shall be ultra-low flush toilets with a maximum tank size or flush capacity of 1.6 gallons, all shower heads shall have a maximum flow capacity of 2.5 gallons per minute, and all hot water faucets that have more than ten feet of pipe between the faucet and the hot water heater serving such faucet shall be equipped with a hot water recirculating system.</p> <p>b. Landscape plans shall apply xeriscape principles, including such techniques and materials as native or low water use plants and low precipitation sprinkler heads, bubblers, drip irrigation systems and timing devices. (Water Resources Agency)</p>	Compliance to be verified by building inspector at final inspection.	Owner/ Applicant	Prior to final building inspection/occupancy	
5		<p>WR3 - DRAINAGE PLAN - RETENTION The applicant shall provide the Water Resources Agency a drainage plan prepared by a registered civil engineer or architect addressing on-site and off-site impacts. The plan shall include retention/percolation facilities to mitigate the impact of impervious surface stormwater runoff. Drainage improvements shall be constructed in accordance with plans approved by the Water Resources Agency. (Water Resources Agency)</p>	Submit 3 copies of the engineered drainage plan to the Water Resources Agency for review and approval.	Owner/ Applicant/ engineer	Prior to issuance of grading or building permits	
6		<p>WR8 - COMPLETION CERTIFICATION The applicant shall provide the Water Resources Agency certification from a registered civil engineer or licensed contractor that stormwater detention/retention facilities have been constructed in accordance with approved plans. (Water Resources Agency)</p>	Submit a letter to the Water Resources Agency, prepared by a registered civil engineer or licensed contractor, certifying compliance with approved drainage plan.	Owner/ Applicant/ Engineer/ Contractor	Prior to final inspection	

<i>Permit Cond. Number</i>	<i>Mitig. Number</i>	<i>Conditions of Approval and/or Mitigation Measures and Responsible Land Use Department</i>	<i>Compliance or Monitoring Actions to be performed. Where applicable, a certified professional is required for action to be accepted.</i>	<i>Responsible Party for Compliance</i>	<i>Timing</i>	<i>Verification of Compliance (name/date)</i>
7		FIRE021 - FIRE PROTECTION EQUIPMENT & SYSTEMS - FIRE SPRINKLER SYSTEM (STANDARD) The building(s) and attached garage(s) shall be fully protected with automatic fire sprinkler system(s). Installation shall be in accordance with the applicable NFPA standard. A minimum of four (4) sets of plans for fire sprinkler systems must be submitted by a California licensed C-16 contractor and approved prior to installation. This requirement is not intended to delay issuance of a building permit. A rough sprinkler inspection must be scheduled by the installing contractor and completed prior to requesting a framing inspection. (Pebble Beach Community Services)	Applicant shall enumerate as "Fire Dept. Notes" on plans.	Applicant or owner	Prior to issuance of building permit.	
			Applicant shall schedule fire dept. rough sprinkler inspection	Applicant or owner	Prior to framing inspection	
			Applicant shall schedule fire dept. final sprinkler inspection	Applicant or owner	Prior to final building inspection	
8		PBD021 - LIGHTING - EXTERIOR LIGHTING PLAN All exterior lighting shall be unobtrusive, harmonious with the local area, and constructed or located so that only the intended area is illuminated and off-site glare is fully controlled. The applicant shall submit 3 copies of an exterior lighting plan which shall indicate the location, type, and wattage of all light fixtures and include catalog sheets for each fixture. The exterior lighting plan shall be subject to approval by the Director of Planning and Building Inspection, prior to the issuance of building permits. (Planning and Building Inspection)	Submit three copies of the lighting plans to PBI for review and approval.	Owner/ Applicant	Prior to issuance of building permits.	

Permit Cond. Number	Mitig. Number	Conditions of Approval and/or Mitigation Measures and Responsible Land Use Department	Compliance or Monitoring Actions to be performed. Where applicable, a certified professional is required for action to be accepted.	Responsible Party for Compliance	Timing	Verification of Compliance (name/date)
9		Non Standard Condition -Exotic Invasive Plants In order to avoid indirect impacts to various sensitive habitat communities, the applicant shall, in an ongoing manner, eradicate all invasive exotic species from impacted areas and ensure that such species do not propagate to undisturbed portions of the subject property. Particular attention shall be focused on iceplant (<i>Carpobrotus edulis</i>). (Planning and Building Inspection)	Applicant shall provide evidence (e.g. photographs) two years after project approval that the project site is kept free of invasive exotic species and that invasive species do not propagate further around the property to the satisfaction of the Director of Planning and Building Inspection.	Owner/ Applicant PBI	Ongoing Two Year Monitoring Report	
10		PBD032(B) – TREE AND ROOT PROTECTION Trees which are located close to the construction site(s) shall be protected from inadvertent damage from construction equipment by fencing off the canopy driplines and/or critical root zones (whichever is greater) with protective materials, wrapping trunks with protective materials, avoiding fill of any type against the base of the trunks and avoiding an increase in soil depth at the feeding zone or drip-line of the retained trees. Said protection shall be demonstrated prior to issuance of building permits subject to the approval of the Director of Planning and Building Inspection. (Planning and Building Inspection)	Submit evidence of tree protection in the form of photos to PBI for review and approval.	Owner/ Applicant	Prior to Issuance of Grading and/or Building Permits	
11		PBD NON-STANDARD – EASEMENT - SCENIC A scenic easement shall be conveyed to the County over those portions of the property located in the front yard setback. A conservation and scenic easement deed (coastal) shall be submitted to, and approved by, the Director of Planning and Building Inspection prior to issuance of grading or building permits. (Planning and Building Inspection)	Submit scenic easement to PBI for review. Submit scenic easement deed to Board for acceptance. Record deed.	Owner/ Applicant PBI	Prior to Issuance of Grading and Building Permits Prior to final inspection	

<i>Permit Cond. Number</i>	<i>Mitig. Number</i>	<i>Conditions of Approval and/or Mitigation Measures and Responsible Land Use Department</i>	<i>Compliance or Monitoring Actions to be performed. Where applicable, a certified professional is required for action to be accepted.</i>	<i>Responsible Party for Compliance</i>	<i>Timing</i>	<i>Verification of Compliance (name/date)</i>
12		<p>PBD NON-STANDARD – FOREST MANAGEMENT PLAN</p> <p>Prior to the issuance of a grading or building permit, the applicant shall submit, and have approved, a forest management plan for the property. For any tree relocation, the forest management plan will include a monitoring program to track the health and status of relocated trees. (Planning and Building Inspection)</p>	Submit forest management plan PBI for review and approval.	Owner/ Applicant	Prior to issuance of grading and building permits	
13		<p>EROSION AND RUNOFF CONTROL</p> <p>Prior to the issuance of a grading or building permit, the applicant shall submit evidence that erosion and runoff control measures have been implemented in accordance with Monterey County's Erosion Control (Chapter 16.12) and Grading (Chapter 16.08) Ordinances. (Planning and Building Inspection)</p>	Submit evidence that erosion and runoff control measures have been implemented in accordance with Monterey County's Erosion Control (Chapter 16.12) and Grading (Chapter 16.08) Ordinances.	Owner/ Applicant	Prior to issuance of grading and building permits	
14		<p>PBD018(A) - LANDSCAPE PLAN (SINGLE FAMILY DWELLING ONLY)</p> <p>The site shall be landscaped. At least 60 days prior to occupancy, three (3) copies of a landscaping plan shall be submitted to the Director of Planning and Building Inspection for approval. A landscape plan review fee is required for this project. Fees shall be paid at the time of landscape plan submittal. The landscaping plan shall be in sufficient detail to identify the location, species, and size of the proposed landscaping materials and shall be accompanied by a nursery or contractor's estimate of the cost of installation of the plan. Such a plan shall address screening structures from 17 Mile Drive. Before occupancy, landscaping shall be either installed or a certificate of deposit or other form of surety made payable to Monterey County for that cost estimate shall be submitted to the Monterey County Planning and Building Inspection Department. (Planning and Building Inspection)</p>	Submit landscape plans and contractor's estimate to PBI for review and approval.	Owner/ Applicant/ Contractor	At least 60 days prior to final inspection or occupancy	

<i>Permit Cond. Number</i>	<i>Mitig. Number</i>	<i>Conditions of Approval and/or Mitigation Measures and Responsible Land Use Department</i>	<i>Compliance or Monitoring Actions to be performed. Where applicable, a certified professional is required for action to be accepted.</i>	<i>Responsible Party for Compliance</i>	<i>Timing</i>	<i>Verification of Compliance (name/date)</i>
15		PBD018(A) - LANDSCAPE MAINTENANCE (SINGLE FAMILY DWELLING ONLY) All landscaped areas and fences shall be continuously maintained by the applicant; all plant material shall be continuously maintained in a litter-free, weed-free, healthy, growing condition. (Planning and Building Inspection)	All landscaped areas and fences shall be continuously maintained by the applicant; all plant material shall be continuously maintained in a litter-free, weed-free, healthy, growing condition.	Owner/ Applicant	Ongoing	
16		PBD014 - GRADING-WINTER RESTRICTION No land clearing or grading shall occur on the subject parcel between October 15 and April 15 unless authorized by the Director of Planning and Building Inspection. (Planning and Building Inspection)	None	Owner/ Applicant	Ongoing	
17		WR43 - WATER AVAILABILITY CERTIFICATION The applicant shall obtain from the Monterey County Water Resources Agency, proof of water availability on the property, in the form of an approved Monterey Peninsula Water Management District Water Release Form. (Water Resources Agency)	Submit the Water Release Form to the Water Resources Agency for review and approval.	Owner/ Applicant	Prior to issuance of any building permits	
18		FIRE008 - GATES All gates providing access from a road to a driveway shall be located at least 30 feet from the roadway and shall open to allow a vehicle to stop without obstructing traffic on the road. Gate entrances shall be at least the width of the traffic lane but in no case less than 12 feet wide. Where a one-way road with a single traffic lane provides access to a gated entrance, a 40-foot turning radius shall be used. Where gates are to be locked, the installation of a key box or other acceptable means for immediate access by emergency equipment may be required. (Pebble Beach Community Services)	Applicant shall incorporate specification into design and enumerate as "Fire Dept. Notes" on plans.	Applicant or owner	Prior to issuance of grading and/or building permit.	

<i>Permit Cond. Number</i>	<i>Mitig. Number</i>	<i>Conditions of Approval and/or Mitigation Measures and Responsible Land Use Department</i>	<i>Compliance or Monitoring Actions to be performed. Where applicable, a certified professional is required for action to be accepted.</i>	<i>Responsible Party for Compliance</i>	<i>Timing</i>	<i>Verification of Compliance (name/date)</i>
			Applicant shall schedule fire dept. clearance inspection	Applicant or owner	Prior to final building inspection	
19		FIRE007 - DRIVEWAYS Driveways shall not be less than 12 feet wide unobstructed, with an unobstructed vertical clearance of not less than 15 feet. The grade for all driveways shall not exceed 15 percent. Where the grade exceeds 8 percent, a minimum structural roadway surface of 0.17 feet of asphaltic concrete on 0.34 feet of aggregate base shall be required. The driveway surface shall be capable of supporting the imposed load of fire apparatus (22 tons), and be accessible by conventional-drive vehicles, including sedans. For driveways with turns 90 degrees and less, the minimum horizontal inside radius	Applicant shall incorporate specification into design and enumerate as "Fire Dept. Notes" on plans.	Applicant or owner	Prior to issuance of grading and/or building permit.	

<i>Permit Cond. Number</i>	<i>Mitig. Number</i>	<i>Conditions of Approval and/or Mitigation Measures and Responsible Land Use Department</i>	<i>Compliance or Monitoring Actions to be performed. Where applicable, a certified professional is required for action to be accepted.</i>	<i>Responsible Party for Compliance</i>	<i>Timing</i>	<i>Verification of Compliance (name/date)</i>
		<p>of curvature shall be 25 feet. For driveways with turns greater than 90 degrees, the minimum horizontal inside radius curvature shall be 28 feet. For all driveway turns, an additional surface of 4 feet shall be added. All driveways exceeding 150 feet in length, but less than 800 feet in length, shall provide a turnout near the midpoint of the driveway. Where the driveway exceeds 800 feet, turnouts shall be provided at no greater than 400-foot intervals. Turnouts shall be a minimum of 12 feet wide and 30 feet long with a minimum of 25-foot taper at both ends. Turnarounds shall be required on driveways in excess of 150 feet of surface length and shall long with a minimum 25-foot taper at both ends. Turnarounds shall be required on driveways in excess of 150 feet of surface length and shall be located within 50 feet of the primary building. The minimum turning radius for a turnaround shall be 40 feet from the center line of the driveway. If a hammerhead/T is used, the top of the "T" shall be a minimum of 60 feet in length.</p> <p>(Pebble Beach Community Services)</p>	Applicant shall schedule fire dept. clearance inspection	Applicant or owner	Prior to final building inspection	
20		<p>FIRE011 - ADDRESSES FOR BUILDINGS</p> <p>All buildings shall be issued an address in accordance with Monterey County Ordinance No. 1241. Each occupancy, except accessory buildings, shall have its own permanently posted address. When multiple occupancies exist within a single building, each individual occupancy shall be separately identified by its own address. Letters, numbers and symbols for addresses shall be a minimum of 4-inch height, 1/2-inch stroke, contrasting with the background color of the sign, and shall be Arabic. The sign and numbers shall be reflective and made of a noncombustible material. Address signs shall be placed at each driveway entrance</p>	Applicant shall incorporate specification into design and enumerate as "Fire Dept. Notes" on plans.	Applicant or owner	Prior to issuance of building permit.	

<i>Permit Cond. Number</i>	<i>Mitig. Number</i>	<i>Conditions of Approval and/or Mitigation Measures and Responsible Land Use Department</i>	<i>Compliance or Monitoring Actions to be performed. Where applicable, a certified professional is required for action to be accepted.</i>	<i>Responsible Party for Compliance</i>	<i>Timing</i>	<i>Verification of Compliance (name/date)</i>
		<p>and at each driveway split. Address signs shall be and visible from both directions of travel along the road. In all cases, the address shall be posted at the beginning of construction and shall be maintained thereafter.</p> <p>Address signs along one-way roads shall be visible from both directions of travel. Where multiple addresses are required at a single driveway, they shall be mounted on a single sign. Where a roadway provides access solely to a single commercial occupancy, the address sign shall be placed at the nearest road intersection providing access to that site. Permanent address numbers shall be posted prior to requesting final clearance. (Pebble Beach Community Services)</p>	Applicant shall schedule fire dept. clearance inspection	Applicant or owner	Prior to final building inspection	

END OF CONDITIONS

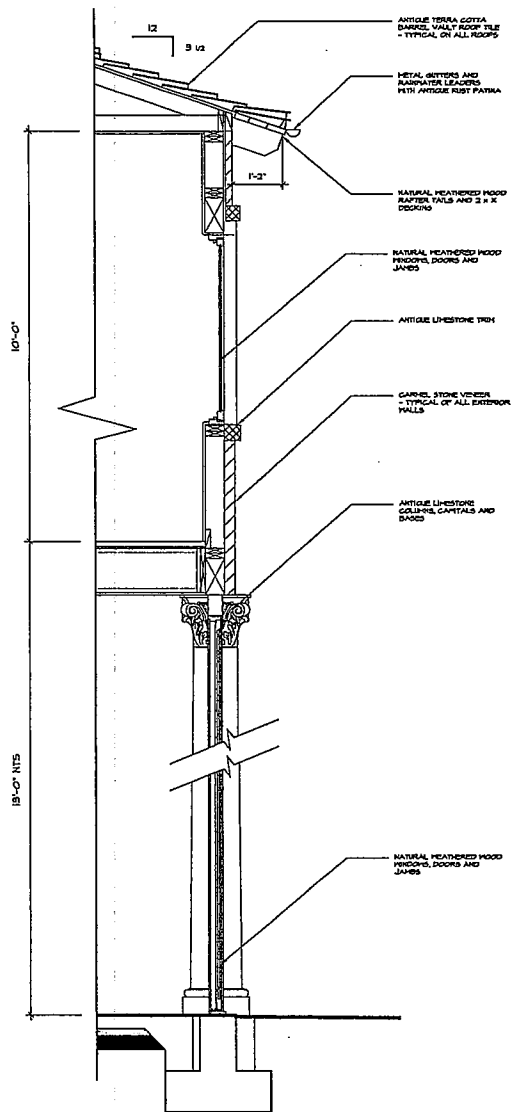

PROJECT INFORMATION

PROPERTY OWNERS: Moll Jones
P.O. Box 644
Pescadero, California 93953
Telephone: 651 / 541 - 1305

DESIGNER: BOLTON DESIGN GROUP, INC.
P.O. Box 5400
Carmel, California 93921
Telephone: 651 / 651 - 6200

PROJECT DESCRIPTION: Replacement of Existing Single Family Dwelling With Detached Two Vehicle Garage and Dwelthouse

SITE ADDRESS: 3365 17 Mile Drive
Pebble Beach, California 93953

APN: 005 - 341 - 001 - 000

LOT & BLOCK: Lot 4 Block 151, El Pescadero RD

ZONING: LDR / IS - D (CZ)

OCCUPANCY: R-S / U-1

BUILDING TYPE: V-N

SPRINKLERED: YES

PROJECT DATA:

LOT SIZE: 43,668.00 SQ. FT.
1.00 ACRES

EXISTING STRUCTURAL SITE COVERAGE:

MAIN HOUSE	3,706.46 SQ. FT.
GAZEBO	125.70 SQ. FT.
TOTAL STRUCTURAL COVERAGE:	3,832.16 SQ. FT. (8.87%)

PROPOSED STRUCTURAL SITE COVERAGE:

MAIN HOUSE - MAIN LEVEL	5,564.27 SQ. FT.
UPPER LEVEL (NOT PART OF PAUL ENCLAVEMENT)	3,234.74 SQ. FT.
DETACHED GARAGE:	344.05 SQ. FT.
GUEST HOUSE:	423.00 SQ. FT.
TOTAL STRUCTURAL COVERAGE (MAX. PER EL. PESCADERO 5,000 SQ. FT.)	4,545.32 SQ. FT. (10.40%)
TOTAL INTERMEDIUM SITE COVERAGE (MAX. PER EL. PESCADERO 4,000 SQ. FT.)	LESS THAN 4,000 SQ. FT.

PROPOSED HEIGHT OF STRUCTURE: NOT TO EXCEED 30'-0"

PROPOSED GRADING ESTIMATE: BALANCE CUT AND FILL

PROPOSED TREE REMOVAL: NONE

SOIL DEVELOPMENT: NONE

CONSULTANTS

Surveyors: Central Coast Surveyors
21919a Court
Suite H-11
Montezuma, California 93940
Telephone: 651 / 544 - 4430
Facsimile: 651 / 544 - 4921

Archaeological Consultants: Bosh Research Associates
1703 Dorte Street
Suite 210
San Leandro, California 94577
Telephone: 510 / 450 - 8444
Facsimile: 510 / 450 - 8445

Civil Consultant: HERTSON ENGINEERS
1414 Blue Larkspur Lane, Suite 109
Hortland, California 93940
Telephone: 651 / 441 - 5225
Facsimile: 651 / 573 - 5205

Soils & Geotechnical Consultant: D & H CONSULTING ENGINEERS, INC.
12 Thomas Greene Way
Hortland, California 93940
Telephone: 651 / 573 - 5716
Facsimile: 651 / 573 - 7428

LOCATION MAP

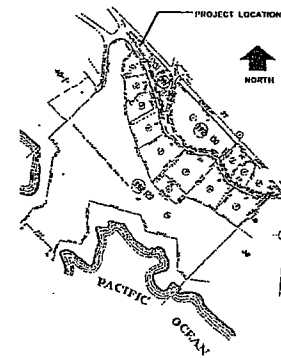

VICINITY MAP

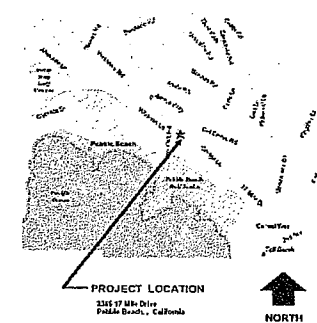

DRAWING SHEET INDEX

A - 01	TITLE SHEET & TYPICAL WALL SECTION
A - 02	EXISTING SITE PLAN
C - 10	PRELIMINARY SITE GRADING AND DRAINAGE PLAN
A - 11	MAIN LEVEL FLOOR PLAN
A - 12	UPPER LEVEL & TERRACE LEVEL FLOOR / ROOF PLANS
A - 13	GUEST HOUSE & GARAGE FLOOR PLANS, ELEVATIONS AND ROOF PLAN
A - 21	EXTERIOR ELEVATIONS
A - 22	EXTERIOR ELEVATIONS

BOLTON
DESIGN
GROUP
INC.

831 659 6200

3365 17 Mile Dr.

**Replacement of
Existing Single
Family Dwelling**

**3365 17 Mile Drive
Pebble Beach
California
93953**

DATE: 21 DEC 2005

REVISION:
14 FEB 2006

TITLE SHEET

SCALE: AS NOTED

DRAWN BY:

CHECKED BY:

DATE: 05.01

SHEET NO: **A - 01**

Do not make drawings. Verify dimensions, measurements and data of building or site. Report errors and questions to BDC, INC. The use of these plans and specifications is restricted to the original job for which they were prepared.

All drawings and written materials appearing here are the property of Bolton Design Group, Inc. and, if used, BDC, Inc. and the same may not be duplicated, used or disclosed without written consent of BDC, INC.

© BOLTON DESIGN GROUP, INC.

1 TYPICAL WALL SECTION
SCALE: 3/4" = 1'-0"

BOLTON
DESIGN
GROUP
INC.

831 659 6200

3365 17 Mile Dr.

Replacement of
Existing Single
Family Dwelling

3365 17 Mile Drive
Pebble Beach
California
95953

DATE: 21 DEC. 2005

REVISIONS:
16 FEB. 2006

EXISTING
SITE PLAN

AS NOTED

MSBL: 0501

SHEET NO. A-02

This drawing is the property of Bolton Design Group, Inc. and shall remain the property of Bolton Design Group, Inc. No part of this drawing may be reproduced or transmitted in any form or by any means, electronic, mechanical, photocopying, recording, or by any information storage and retrieval system, without the prior written permission of Bolton Design Group, Inc.

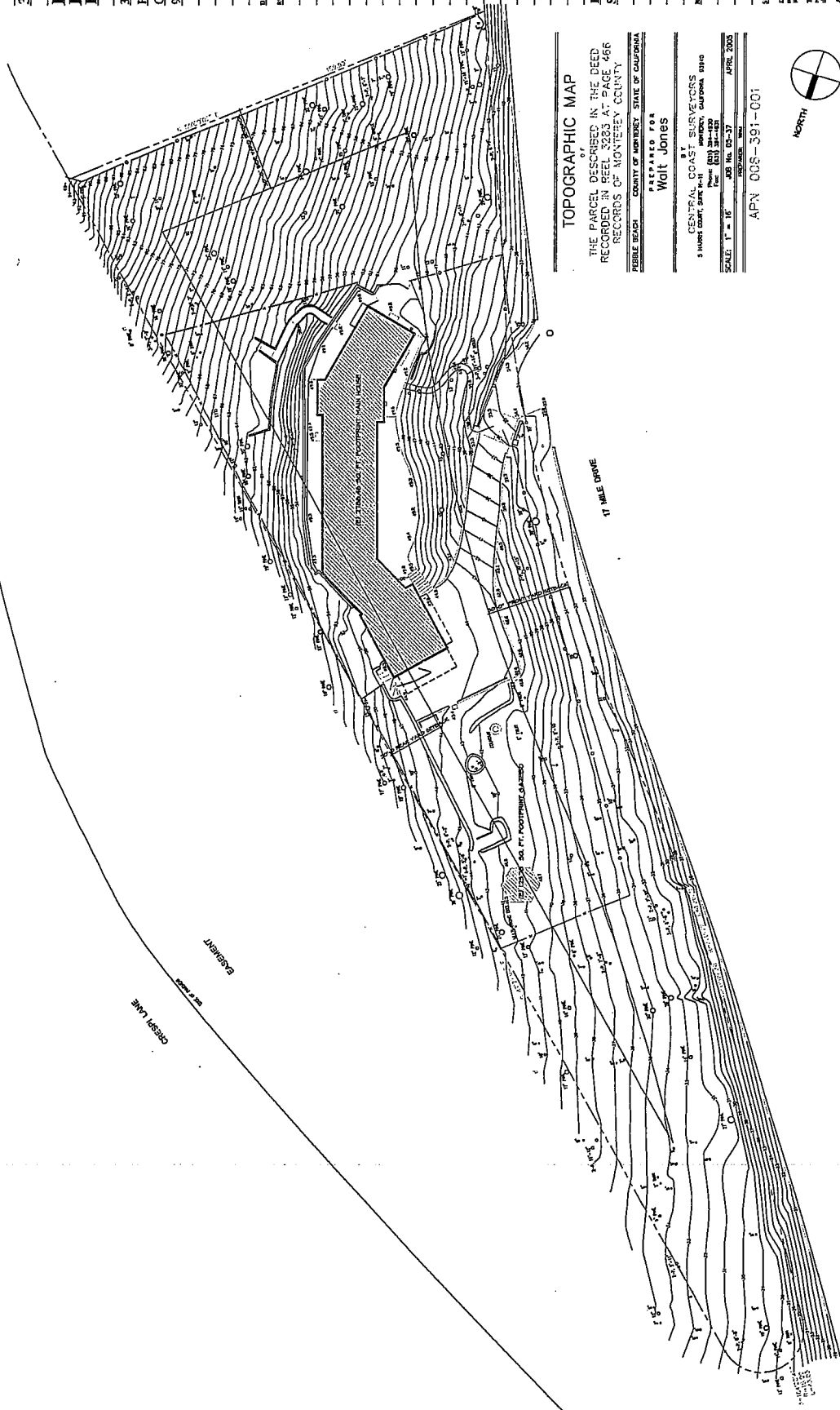

TOPOGRAPHIC MAP

THE PARCEL DESCRIBED IN THE DEED
RECORDED IN REEL 2083 AT PAGE 466
RECORDS OF MONTEREY COUNTY

PEBBLE BEACH COUNTY OF MONTEREY STATE OF CALIFORNIA

PREPARED FOR
Walt Jones

BY

CENTRAL COAST SURVEYORS
11000 Coast Street, Suite 100
Pebble Beach, California 95960

SCALE: 1" = 16'
JOB NO. 05-37 APRIL 2005

APN: 006-391-001



1 EXISTING SITE PLAN

SCALE: 1/16"=1'-0"



GENERAL NOTES

1. THIS PLAN IS FOR PLANNING PURPOSES ONLY. ALL GRADING SHALL CONFORM WITH THE MONTEREY COUNTY GRADING ORDINANCE #2335 AND EROSION CONTROL ORDINANCE #2805.

2. ESTIMATED EARTHWORK: 310 CY CUT AND 215 CY FILL. EXCESS EARTHWORK SHALL BE TAKEN TO A COUNTY APPROVED DISPOSAL SITE. VALUES PRESENTED ARE ESTIMATES ONLY. VALUES SHOULD BE REEVALUATED DURING THE EARLY STAGES OF SITE GRADING TO INSURE THE BALANCE OF CUT AND FILL QUANTITIES (LOADING AND SHRINKAGE ARE ANTICIPATED). SITE SPOOLS SUCH AS FOUNDATIONS, RETAINING WALLS, UTILITY TRENCHING, ETC. ARE NOT ACCOUNTED FOR IN ABOVE VOLUMES.

3. SLOPES OF EXISTING AND PROPOSED TERRACES SHALL BE MAINTAINED TO THE MAXIMUM EXTENT POSSIBLE. ALL GRADING SHALL BE DONE IN ACCORDANCE WITH THE MONTEREY COUNTY GRADING ORDINANCE #2335 AND EROSION CONTROL ORDINANCE #2805. ALL GRADING SHALL BE DONE IN ACCORDANCE WITH THE MONTEREY COUNTY GRADING ORDINANCE #2335 AND EROSION CONTROL ORDINANCE #2805.

4. DOWNSPOUTS AND ROOF DRAINS SHALL BE CONNECTED TO SOLID PIPES AND DISCHARGED INTO A DRAINAGE FACILITY.

5. IMPROVEMENTS SHOWN OUTSIDE OF PROPERTY SHALL OBTAIN PERMITS FROM THE BEACH COMPANY APPROVALS PRIOR TO CONSTRUCTION.

EROSION CONTROL NOTES

1. ALL SURFACES EXPOSED OR EXPECTED TO BE EXPOSED DURING GRADING ACTIVITIES SHALL BE PROTECTED AND MAINTAINED THROUGH THE LENGTH OF THE ENTIRE PROJECT TO PROTECT AGAINST EROSION.

2. ACTUAL GRADING SHALL BEGIN WITHIN 30 DAYS OF VEGETATION REMOVAL OR THE AREA SHALL BE PLANTED TO CONTROL EROSION.

3. THE FOLLOWING PROVISIONS SHALL APPLY BETWEEN OCTOBER 15 AND APRIL 15.

A. DISTURBED SURFACES NOT INVOLVED IN THE MANDATED OPERATIONS MUST BE PROTECTED BY APPLYING STRAW MULCH AT 2000 LBS. PER ACRE AND TUCKED IN TO PREVENT MOVEMENT DURING WINTER FLOWS.

B. ALL ROADS AND DRIVEWAYS SHALL HAVE DRAINAGE FACILITIES SUFFICIENT TO PREVENT EROSION ON OR ADJACENT TO THE ROADWAY OR ON THE DOWNHILL PROPERTIES.

C. RUNOFF FROM THE SITE SHALL BE DETAINED OR FILTERED BY BERMS, VEGETATED FILTER STRIPS AND/OR CATCH BASINS TO PREVENT THE ESCAPE OF SEDIMENT FROM THE SITE.

D. DRAINAGE CONTROL MEASURES SHALL BE MAINTAINED AND IN PLACE AT THE END OF EACH DAY AND CONTINUOUSLY THROUGHOUT THE LIFE OF THE PROJECT DURING WINTER OPERATIONS.

E. THE BUILDING INSPECTOR SHALL STOP OPERATIONS DURING PERIODS OF INCLEMENT WEATHER IF HE DETERMINES THAT EROSION PROBLEMS ARE NOT BEING CONTROLLED ADEQUATELY.

4. AT ALL TIMES DURING CONSTRUCTION AND UNTIL FINAL COMPLETION, THE CONTRACTOR, WHEN HIS OR HIS SUBCONTRACTORS ARE OPERATING EQUIPMENT ON THE SITE, SHALL PREVENT THE FORMATION OF AN AIRBORNE DUST NUISANCE BY WATERING AND/OR TREATING THE SITE OF THE WORK IN SUCH A MANNER THAT WILL CONTAIN DUST PARTICLES TO THE IMMEDIATE SURFACE OF THE WORK. THE CONTRACTOR WILL BE RESPONSIBLE FOR ANY DAMAGE DONE BY DUST FROM HIS OR HER SUBCONTRACTOR.

TYPICAL DRIVEWAY SECTION

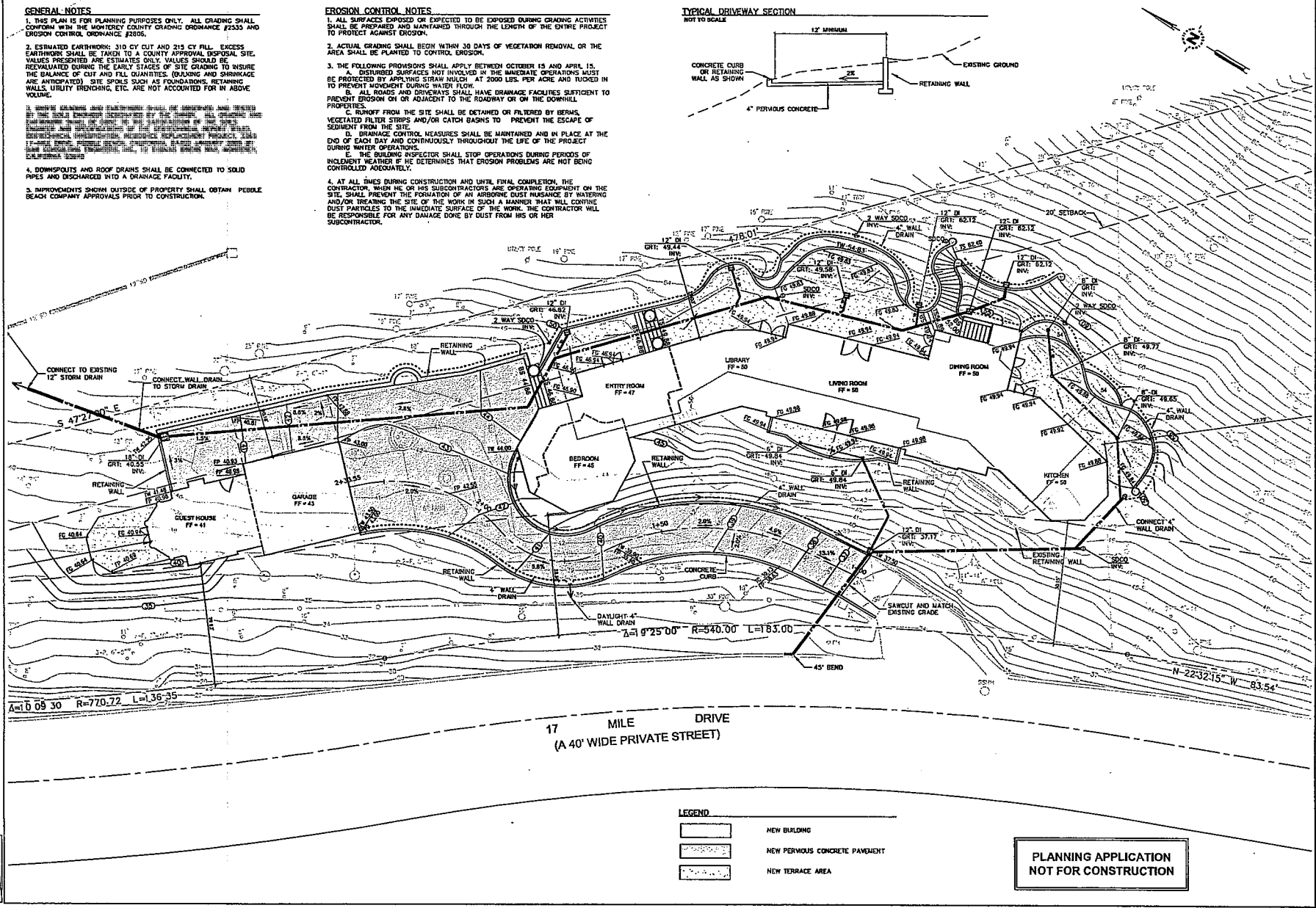
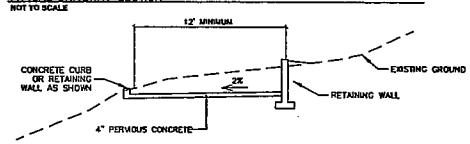

LEGEND

[Symbol: Dotted pattern]	NEW BUILDING
[Symbol: Stippled pattern]	NEW PERVIOUS CONCRETE PAVEMENT
[Symbol: Dashed pattern]	NEW TERRACE AREA

**PLANNING APPLICATION
NOT FOR CONSTRUCTION**

WHITSON ENGINEERS
 8889 Blue Lagoon Lane • Suite 105 • Monterey, CA 93940
 831.945.5223 • FAX 831.932.5085
 Civil Engineering • Land Surveying • Project Management

DATE: FEB. 16, 2009
 SCALE: 1" = 10'
 DRAWN BY: G.C.
 TITLE: PRELIMINARY SITE GRADING AND DRAINAGE PLAN

3365 17-MILE DRIVE
 MONTEREY COUNTY, CALIFORNIA

REVISIONS:

NO.	DATE	DESCRIPTION

SHEET **C-1.0**
 OF 1

CRITERIA FOR GUESTHOUSE

- 1. Only one guesthouse shall be allowed per lot.
 - 2. Detached guesthouses shall be located in close proximity to the principal residence.
 - 3. Guesthouses shall share the same utilities with the main residence, unless prohibited by public health requirements.
 - 4. The guesthouse shall contain no kitchen or cooking facilities, including but not limited to microwave ovens, hot plates, and toaster ovens.
 - 5. There shall be a maximum of 6 linear feet of counter space, excluding counter space in a bathroom. There shall be a maximum of 8 square feet of cabinet space, excluding clothes closets.
 - 6. Guesthouses shall not exceed 425 square feet of livable floor area.
 - 7. Guesthouses shall not be separately rented, let or leased from the main residence whether compensation be direct or indirect.
 - 8. Prior to the issuance of permits for guesthouse construction, or for use of an existing structure as a guesthouse, the applicant shall record a deed restriction stating the regulations applicable to the guesthouse, including that the guesthouse shall not be separately rented, let or leased from the main residence and shall not have cooking or kitchen facilities.
 - 9. Subsequent subdivisions which divide a main residence from a guesthouse shall not be permitted.
 - 10. The guesthouse shall be designed in such a manner as to be visually consistent and compatible with the main residence or site and other residences in the area.
 - 11. The guesthouse height shall not exceed 12 feet nor be more than 1 story.
 - 12. Additions to height and placement of guesthouses over a 1-story structure, such as a garage, may be considered by Coastal Development Permit (CDP) when intended to provide for architectural consistency and compatibility with the main residence.
- See Sheet A - 1B for Guesthouse Floorplan, Elevations and Roof Plan.

BOLTON
DESIGN
GROUP
INC.

831 659 6200

3365 17 Mile Dr.

**Replacement of
Existing Single
Family Dwelling**

**3365 17 Mile Drive
Pebble Beach
California
93953**

DATE: 21 DEC 2005

REVISIONS:
16 FEB 2006

**MAIN LEVEL
FLOOR PLAN**

SCALE: 1/8" = 1'-0"
DRAWN BY:
CHECKED BY:
DATE: 05.01

SHEET NO: **A-1.1**

Do not scale drawings. Verify dimensions, measurements and data in building or site. Report errors and questions to BLDG, INC.

The use of these plans and specifications is restricted to the original use for which they were prepared.

All drawings and written material appearing here are the property of Bolton Design Group, Inc. and its use may not be duplicated, used or disclosed without written consent of BLDG, INC.

© BOLTON DESIGN GROUP, INC.

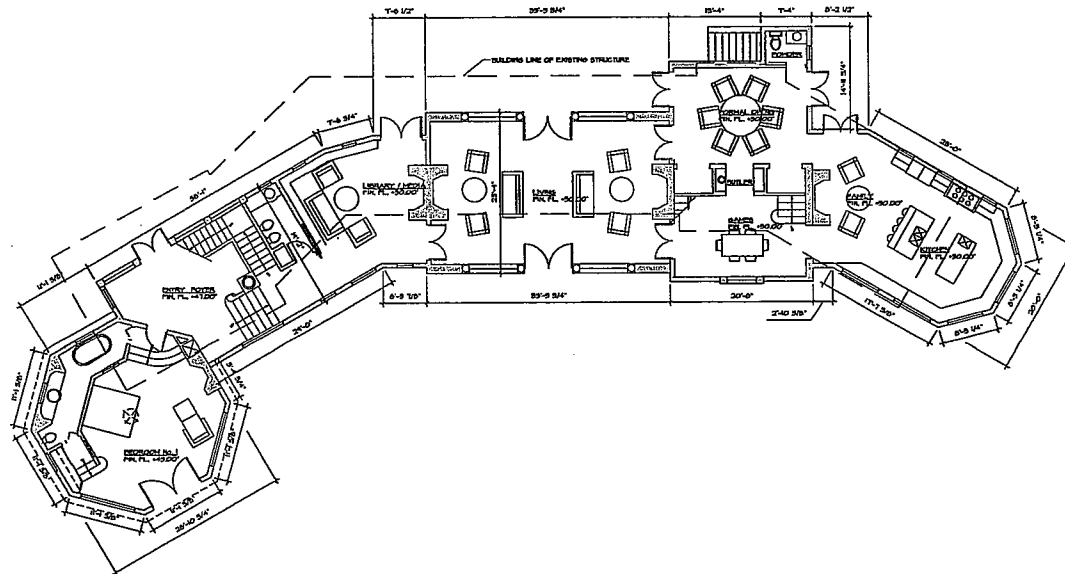

1 MAIN LEVEL FLOOR PLAN
SCALE: 1/8" = 1'-0"

BOLTON
DESIGN
GROUP
INC.

831 659 6200

3365 17 Mile Dr.

Replacement of
Existing Single
Family Dwelling

3365 17 Mile Drive
Pebble Beach
California
93953

DATE: 21 DEC 2005

REVISIONS:

16 FEB 2006

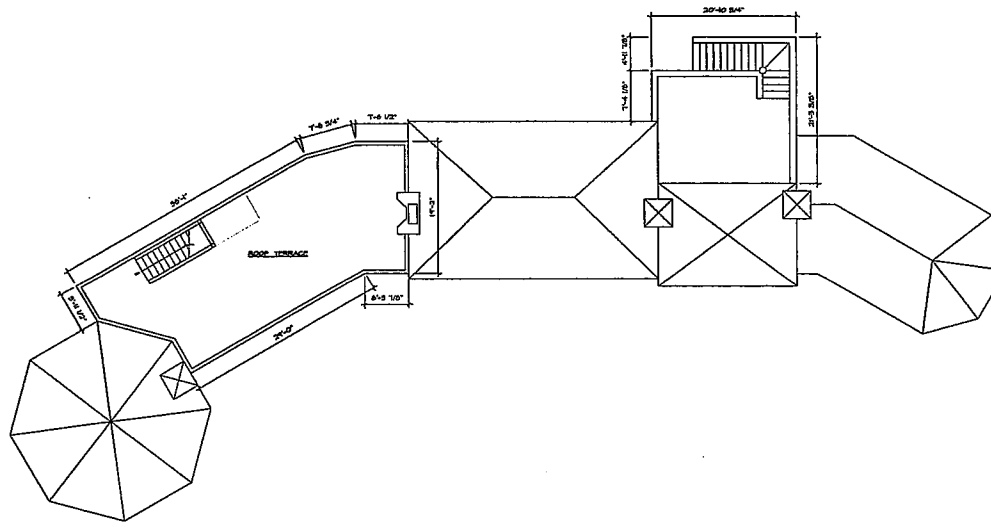

2 TERRACE LEVEL FLOOR/ROOF PLAN

SCALE: 1/8" = 1'-0"

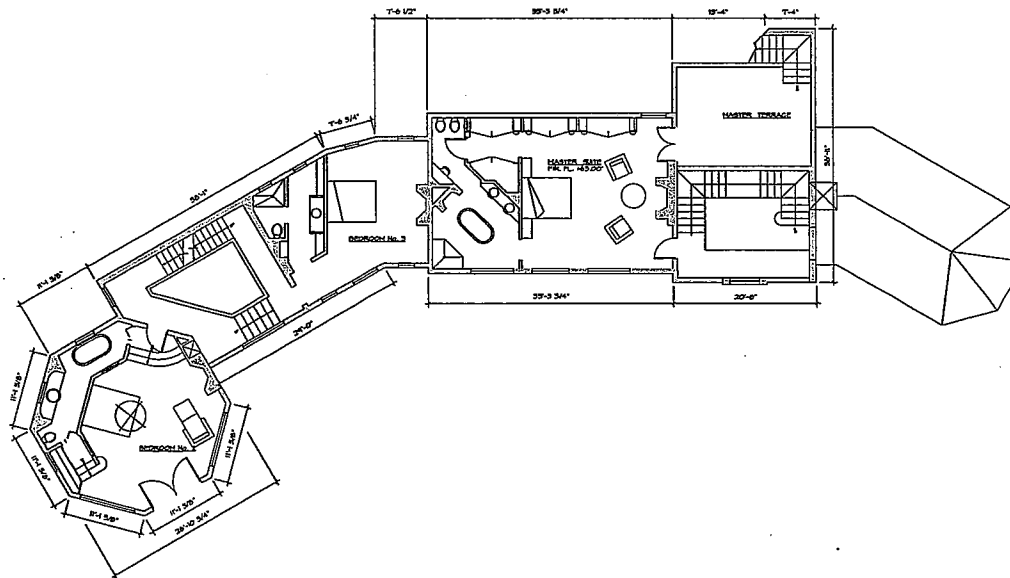

1 UPPER LEVEL FLOOR PLAN

SCALE: 1/8" = 1'-0"

UPPER LEVEL &
TERRACE LEVEL
FLOOR/ROOF
PLANS

SCALE: 1/8" = 1'-0"

DRAWN BY:

CHECKED BY:

DATE: 05.01

SHEET NO: A-12

Do not scale drawings. Verify dimensions, measurements and areas on the building or site. Report errors and omissions to BDLG, INC. The use of these plans and specifications is restricted to the original job for which they were prepared.

All drawings and written material prepared here to constitute the original and approved work of BDLG, INC. and the same may not be duplicated, used or disclosed without written consent of BDLG, INC.

© BOLTON DESIGN GROUP, INC.



3365 17 Mile Dr.

Replacement of
Existing Single
Family Dwelling

3365 17 Mile Drive
Pebble Beach
California
93953

DATE: 21 DEC 2005

REVISIONS:
16 FEB 2006

GUEST HOUSE
& GARAGE
FLOOR PLANS
& ELEVATIONS

SCALE: 1/8" = 1'-0"

DRAWN BY:

CHECKED BY:

DATE: 05.01

SHEET NO: A-13

Do not scale drawings. Verify dimensions, measurements and data on building or site. Repeat errors and omissions to BDC, INC. The use of these plans and specifications is restricted to the original site for which they were prepared.

All drawings and working material appearing here is the property of Bolton Design Group, Inc. and the user may not be duplicated, used or distributed without written consent of BDC, INC.

© BOLTON DESIGN GROUP, INC.

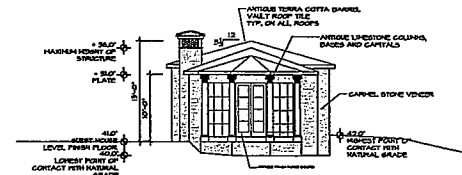

3 NORTH ELEVATION
SCALE: 1/8" = 1'-0"

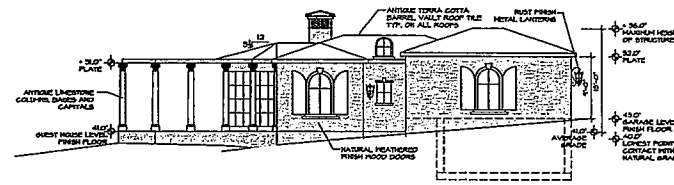

2 WEST ELEVATION
SCALE: 1/8" = 1'-0"

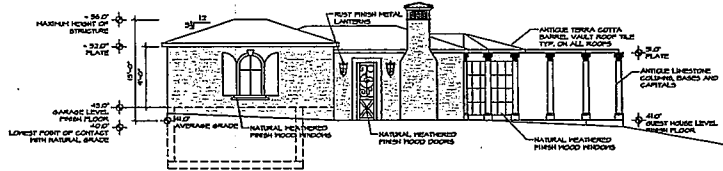

6 EAST ELEVATION
SCALE: 1/8" = 1'-0"

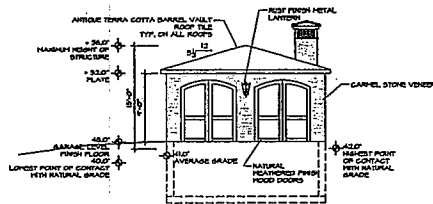

5 SOUTH ELEVATION
SCALE: 1/8" = 1'-0"

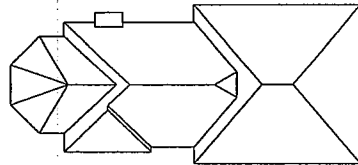

4 ROOF PLAN
SCALE: 1/8" = 1'-0"

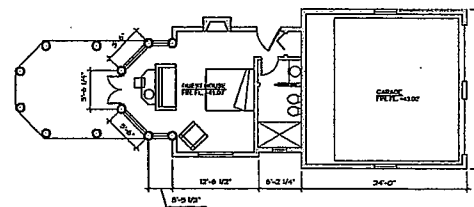

1 GUEST HOUSE & GARAGE FLOOR PLANS
SCALE: 1/8" = 1'-0"



BOLTON
DESIGN
GROUP
INC.

831 659 6200

3365 17 Mile Dr.

Replacement of
Existing Single
Family Dwelling

3365 17 Mile Drive
Pebble Beach
California
93953

DATE: 21 DEC 2005

REVISION:
16 FEB 2006



2 NORTH ELEVATION
SCALE: 1/8" = 1'-0"

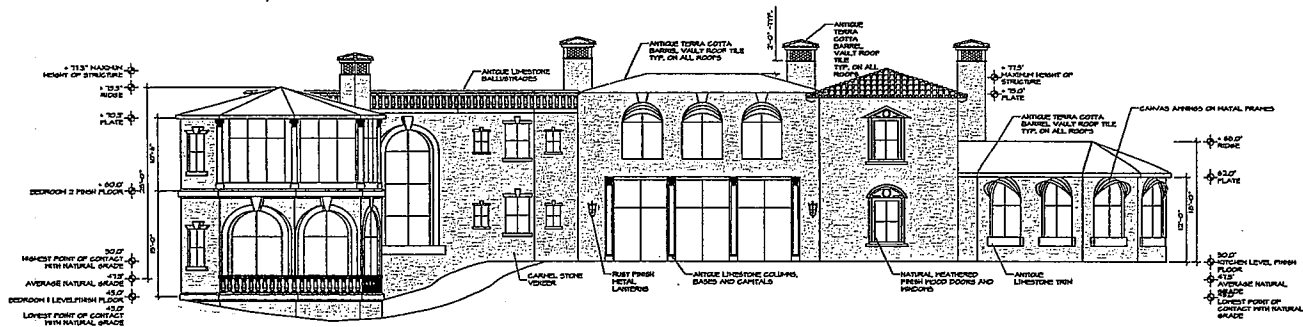

1 WEST ELEVATION
SCALE: 1/8" = 1'-0"

MAIN RESIDENCE
ELEVATIONS

SCALE: 1/8" = 1'-0"

DRAWN BY:

CHECKED BY:

REV NO: 05.01

SHEET NO: A-2.1

Do not underdevelop. Verify dimensions, measurements and data as indicated or else. Report errors and omissions to BDG, INC. The use of these plans and specifications is confined to the subject site for which they were prepared.

All drawings and written material appearing here by constitute the original and reproduced work of BDG, INC. and the user may not be duplicated, used or disclosed without written consent of BDG, INC.

© BOLTON DESIGN GROUP, INC.

BOLTON
DESIGN
GROUP
INC.

831 659 6200

3365 17 Mile Dr.

Replacement of
Existing Single
Family Dwelling

3365 17 Mile Drive
Pebble Beach
California
93953

DATE: 21 DEC 2005

REVISIONS:

16 FEB 2006

MAIN RESIDENCE
ELEVATIONS

SCALE: 1/8" = 1'-0"

DRAWN BY:

CHECKED BY:

JOB NO.: RS-01

SHEET NO.: A-2.2

Do not write drawings. Verify dimensions, annotations and data on building or site. Report errors and questions to BDO, INC. The use of these plans and specifications is restricted to the original site for which they were prepared.

All drawings and written material appearing here is prepared, designed and copyrighted work of BDO, INC. and the same may not be duplicated, used or disclosed without written consent of BDO, INC.

© BOLTON DESIGN GROUP, INC.

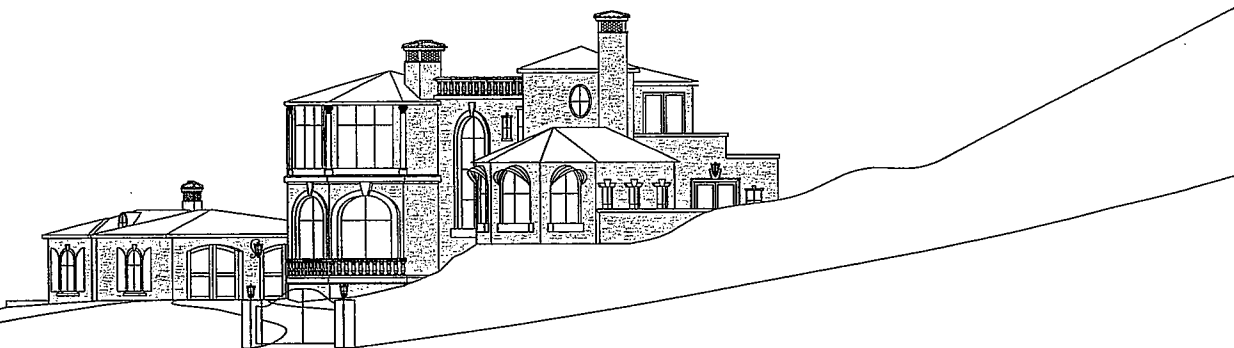

2 SOUTH ELEVATION
SCALE: 1/8" = 1'-0"



1 EAST ELEVATION
SCALE: 1/8" = 1'-0"