

In the matter of the application of
Stephen Kirby and Laura Reyna (PLN060254)

FINDINGS & DECISION

for a Use Permit in accordance with Title 21 (Zoning) Chapter 21.74 (Use Permits) of the Monterey County Code, for the removal of 8 protected oak trees, one Pacific Madrone, and to allow the construction of the 915 square foot one-story single family dwelling with a detached 900 square foot garage, 1,841 square feet of decking and porches, the installation of a septic system, and grading (approx. 45 cu. yds. cut / 0 cu. yds. fill). The property is located at 38892 Tassajara Road, Carmel Valley, Cachagua Area Plan, and came on regularly for hearing before the Zoning Administrator on September 14, 2006.

Said Zoning Administrator, having considered the application and the evidence presented relating thereto,

FINDINGS OF FACT

1. **FINDING: CONSISTENCY** – The project, as described in Condition No. 1 and as conditioned, conforms to the policies, requirements, and standards of the Monterey County General Plan, Cachagua Area Plan, Cachagua Area Plan Inventory and Analysis, and the Monterey County Zoning Ordinance (Title 21), which designates this area as appropriate for development.

EVIDENCE: (a) The text, policies, and regulations in the above referenced documents have been evaluated during the course of review of applications. No conflicts were found to exist. No communications were received during the course of review of the project indicating any inconsistencies with the text, policies, and regulations in these documents.

(b) The property is located at 38892 Tassajara Road, Carmel Valley (Assessor's Parcel Number 418-311-008-000), Cachagua Area Plan. The parcel is zoned or [Resource Conservation with a Building Site zoning district overlay] ("RC/B-6"). The subject property complies with all the rules and regulations pertaining to zoning uses and any other applicable provisions of Title 21, and is therefore suitable for the proposed development.

(c) The project planner conducted a site inspection on May 3, 2006 to verify that the project on the subject parcel conforms to the plans listed above.

(d) The project for a single-family dwelling with detached garage is a use allowed use in accordance with Section 21.36.030.A and is consistent with the development standards of Section 21.36.060.

(e) The removal of eight protected oak trees requires a Use Permit in accordance with Section 21.64.260.D.3. See Finding No. 3.

(f) The project was reviewed by the Cachagua Land Use Advisory Committee (LUAC) on June 19, 2006. The LUAC recommended approval of the project by a vote of 4-0 with two members absent (Exhibit E of the September 14, 2006 staff report). No changes were recommended.

(g) The application, project plans, and related support materials submitted by the project applicant to the Monterey County RMA - Planning Department for the proposed development found in Project File PLN060254.

2. **FINDING: SITE SUITABILITY** – The site is physically suitable for the use proposed.

- EVIDENCE:** (a) The project has been reviewed for site suitability by the following departments and agencies: RMA - Planning Department, Cachagua Fire Protection District, Public Works, Environmental Health Division, and Water Resources Agency. There has been no indication from these departments/agencies that the site is not suitable for the proposed development. Conditions recommended have been incorporated.
- (b) Technical reports by outside biological, archaeological, and geotechnical consultants indicated that there are no physical or environmental constraints that would indicate that the site is not suitable for the use propose. County staff concurs. The following reports have been prepared:
- i. "Biological Assessment for Kirby/Reyna Construction Project, Tassajara Road, Carmel Valley, CA APN 418-311-008" (LIB060300) prepared by Rana Creek Habitat Restoration, Carmel Valley, CA, May 31, 2006;
 - ii. "Forest Management Plan for Residential Parcel APN 418-311-008, 38893 Tassajara Road" (LIB060299), prepared by Matt Horowitz, Forest City Consulting, Carmel, CA, June 6, 2006;
 - iii. "Geotechnical Soils-Foundation and Geoseismic Report for the proposed single family dwelling Tassajara Road, Carmel Valley, CA APN 418-311-008" (LIB060301), prepared by Grice Engineering and Geology Inc., Salinas, CA, September 2005.
- (c) The project site is within an area of moderate archaeological sensitivity according to County resource maps. Staff Archeologist conducted a site inspection on May 3, 2006 to verify that no evidence of historic or prehistoric cultural activity was observed on-site and the parcel does not contain significant cultural resources of a prehistoric nature. A standard condition of approval has been incorporated requiring work stop in the event that an archaeological find is discovered, until a qualified archaeological professional is able to conduct a field reconnaissance and recommend appropriate action to the County.
- (d) The site is located in an area designated as having "low" landslide, "high" erosion, susceptibility and within an "relatively unstable uplands" or very high seismic hazard zone. The geotechnical report prepared for this parcel accounts for these high hazards. A condition of approval has been incorporated requiring that a geotechnical certification be submitted to the Director of the RMA - Planning Department for review and approval prior to final building inspection.
- (e) County staff circulated an Initial Study and Mitigated Negative Declaration for the project (PLN060254/Kirby/Reyna) in compliance with the California Environmental Quality Act (CEQA) and its Guidelines. The Initial Study provides substantial evidence that the project, with the addition of Mitigation Measures, would not have significant environmental impacts. A Mitigated Negative Declaration was filed with the County Clerk June 28, 2006, noticed for public review, and circulated to the State Clearinghouse from June 28, 2006 to August 28, 2006.
- (f) Staff conducted a site inspection on May 3, 2006 to verify that the site is suitable for this use.
- (g) Materials in Project File PLN060254.

3. FINDING: TREE REMOVAL (Minimum Required and Adverse Environmental Impacts) – The proposed tree removal is consistent with Section 21.64.260.D. Tree removal is the minimum required under the circumstances of the case and will not involve a risk of adverse environmental impacts. The project proposes the removal of eleven trees of which nine are protected. Tree removal consists of five Valley Oaks, one Coast Live Oak, four Valley Oak-Coast Live Oak hybrids, and one Pacific Madrone.

- EVIDENCE:** (a) A letter submitted by the applicants (Exhibit F of the September 14, 2006 staff report), dated June 5, 2006, describes that the residence has been sited in the most appropriate location within the homeland boundary considering the following factors: (1) the need for the driveway to meet fire department code requirements of less than 15% slope for fire vehicles and provide for emergency vehicle truck turn-around requirements; and (2) the limited area within the building envelope on slopes less than 30% suitable for a septic system and disposal fields. Trees designated for removal lie within the footprint of the proposed residence.
- (b) The Forest Management Plan, Matt Horowitz, Forest City Consulting, Carmel, CA, June 6, 2006 (Library No. LIB060299) indicates that tree removal is limited to those trees within the footprint of construction. The reports suggests that tree removal will not involve a risk of adverse environmental impacts such as soil erosion, water quality, ecological impacts, noise pollution, air movement, and wildlife habitat. Tree removal will not have a negative impact on soil erosion. Compliance with Monterey County Erosion Control Measures will be required during construction activities.
- (c) The Monterey County Zoning Ordinance, Section 21.64.260.D.4 requires the replacement of protected tree species removed at a rate of 1:1 replacement ratio. However, the Forest Management Plan recommends, as Mitigation Measure No. 5 that no trees or vegetation be planted, or any fill be placed under the canopy of existing large oak trees to promote native regeneration of the Mixed Oak Woodland.
- (d) The application, plans, and related support materials submitted by the project applicant to the Monterey County RMA - Planning Department for the proposed development, found in Project File PLN060254.

4. FINDING: CEQA: On the basis of the whole record before the Monterey County Zoning Administrator, there is no substantial evidence that the proposed project as designed, conditioned, and mitigated, will have a significant effect on the environment. The Mitigated Negative Declaration reflects the independent judgment and analysis of the County.

- EVIDENCE:** (a) The proposed project is subject to environmental review due to the potential for significant environmental effects pursuant to CEQA Guidelines Section 15070 (Decision to Prepare a Negative or Mitigated Negative Declaration).
- (b) Potentially adverse environmental effects were identified during staff review of the development application.
- (c) Monterey County prepared an Initial Study pursuant to CEQA. The Initial Study is on file in the office of the Planning and Building Inspection Department and is hereby incorporated by reference (File No. PLN060254). All project changes required to avoid significant effects on the environment have been incorporated into the project and/or are made conditions of approval. The Initial Study identified potentially significant effects

relative to Biological Resources, Geology/Soils, Hazards/ Hazardous Materials, and Hydrology/Water Quality. Substantial evidence supports the conclusion that impacts will be less than significant with mitigation incorporated for these issues.

- (d) The Mitigated Negative Declaration was circulated for public review from July 28, 2006 to August 28, 2006.
- (e) One comment letter was received from the Monterey Bay Unified Air Pollution Control District (MBUAPCD) prior to the close of the comment period. The letter, attached as Exhibit I in the September 14, 2006 staff report, serves to clarify statements made in the Air Quality Section, on page 14 of the Initial Study.
- (f) The Monterey County Planning Department, located at 168 W. Alisal Street, 2nd Floor, Salinas, CA, 93901, is the custodian of documents and other materials that constitute the record of proceedings upon which the decision to adopt the Mitigated Negative Declaration is based.
- (g) A Mitigation Monitoring and Reporting Program (MMRP) has been prepared and is designed to ensure compliance with conditions and that mitigation measures are monitored and reported during project implementation. The applicant must enter into an "Agreement to Implement a Mitigation Monitoring and Reporting Program" as a condition of project approval.
- (h) For purposes of implementing Section 753.5 of Title 14, California Code of Regulations, the project may cause changes to the resources listed under Section 753.5. Therefore, payment of the Fish and Game fee is required.
- (i) Evidence that has been received and considered includes the application, plans, materials, and technical reports, which are listed under Section IX (References) of the Initial Study and contained in project file PLN060254.

5. FINDING: NO VIOLATIONS - The subject property is in compliance with all rules and regulations pertaining to zoning uses, subdivision, and any other applicable provisions of the County's zoning ordinance. No violations exist on the property. Zoning violation abatement costs, if any, have been paid.

EVIDENCE: (a) Staff reviewed Monterey County RMA - Planning Department and Building Services Department records and is not aware of any violations existing on subject property.
(b) Staff conducted a site inspection on May 3, 2006 to verify that the subject property is in compliance with all rules and regulations pertaining to zoning uses, subdivision, and any other applicable provisions of the County's zoning ordinance.

6. FINDING: HEALTH AND SAFETY - The establishment, maintenance, or operation of the project applied for will not under the circumstances of this particular case be detrimental to the health, safety, peace, morals, comfort, and general welfare of persons residing or working in the neighborhood of such proposed use, or be detrimental or injurious to property and improvements in the neighborhood or to the general welfare of the County.

EVIDENCE: Preceding findings and supporting evidence.

7. FINDING: APPEALABILITY - The decision on this project is appealable to the Planning Commission.

EVIDENCE: Section 21.080.040.B Monterey County Zoning Ordinance (Title 21).

DECISION

THEREFORE, it is the decision of the Zoning Administrator of the County of Monterey that the Mitigated Negative Declaration and Program for Mitigation Monitoring and/or Reporting on Conditions of Approval be adopted and said application for a Use Permit be granted as shown on the attached sketch and subject to the attached conditions.

PASSED AND ADOPTED this 14th day of September, 2006.



JEFF MAIN, ZONING ADMINISTRATOR

COPY OF THIS DECISION WAS MAILED TO THE APPLICANT ON OCT - 4 2006

IF ANYONE WISHES TO APPEAL THIS DECISION, AN APPEAL FORM MUST BE COMPLETED AND SUBMITTED TO THE SECRETARY TO THE PLANNING COMMISSION ALONG WITH THE APPROPRIATE FILING FEE ON OR BEFORE OCT 14 2006

This decision, if this is the final administrative decision, is subject to judicial review pursuant to California Code of Civil Procedure Sections 1094.5 and 1094.6. Any Petition for Writ of Mandate must be filed with the Court no later than the 90th day following the date on which this decision becomes final.

NOTES

1. You will need a building permit and must comply with the Monterey County Building Ordinance in every respect.

Additionally, the Zoning Ordinance provides that no building permit shall be issued, nor any use conducted, otherwise than in accordance with the conditions and terms of the permit granted or until ten days after the mailing of notice of the granting of the permit by the appropriate authority, or after granting of the permit by the Board of Supervisors in the event of appeal.

Do not start any construction or occupy any building until you have obtained the necessary permits and use clearances from the Monterey County Planning and Building Inspection Department office in Salinas.

2. This permit expires two years after the above date of granting thereof unless construction or use is started within this period.

**Monterey County Resource Management Agency
Planning Department
Condition Compliance and/or Mitigation Monitoring
Reporting Plan**

Project Name: Stephen Kirby and Laura Reyna
File No: PLN060254 **APN:** 418-311-008-000
Approved by: Zoning Administrator **Date:** September 14, 2006

**Monitoring or Reporting refers to projects with an EIR or adopted Mitigated Negative Declaration per Section 21081.6 of the Public Resources Code.*

<i>Permit Cond. Number</i>	<i>Mitig. Number</i>	<i>Conditions of Approval and/or Mitigation Measures and Responsible Land Use Department</i>	<i>Compliance or Monitoring Actions to be performed. Where applicable, a certified professional is required for action to be accepted.</i>	<i>Responsible Party for Compliance</i>	<i>Timing</i>	<i>Verification of Compliance (name/date)</i>
1.		<p>PBD029 - SPECIFIC USES ONLY This Use Permit (PLN060254) allows the removal of 8 protected oak trees, one Pacific Madrone, and allows the construction of a 915 square foot one-story single family dwelling with a detached 900 square foot garage, 1,841 square feet of decking and porches, the installation of a septic system, and grading (approx. 45 cu. yds. cut / 0 cu. yds. fill). The property is located at 38892 Tassajara Road, Carmel Valley (Assessor's Parcel Number 418-311-008-000), Cachagua Area Plan. This permit was approved in accordance with County ordinances and land use regulations subject to the following terms and conditions. Neither the uses nor the construction allowed by this permit shall commence unless and until all of the conditions of this permit are met to the satisfaction of the Director of RMA - Planning Department. Any use or construction not in substantial conformance with the terms and conditions of this permit is a violation of County regulations and may result in modification or revocation of this permit and subsequent legal action. No use or construction other than that specified by this permit is allowed unless additional permits are approved by the appropriate authorities. [Resource Management Agency (RMA) - Planning Department]</p>	Adhere to conditions and uses specified in the permit.	Owner/ Applicant	Ongoing unless otherwise stated	

2.	<p>PBD025 - NOTICE-PERMIT APPROVAL The applicant shall record a notice, which states: "A permit (Resolution No. PLN060254) was approved by the Zoning Administrator for Assessor's Parcel Number 418-311-008-000 on September 14, 2006. The permit was granted subject to 37 conditions of approval, which run with the land. A copy of the permit is on file with the Monterey County RMA - Planning Department." Proof of recordation of this notice shall be furnished to the Director of RMA - Planning Department prior to issuance of building permits or commencement of the use. (RMA - Planning Department)</p>	Proof of recordation of this notice shall be furnished to RMA - PD	Owner/ Applicant	Prior to Issuance of grading and building permits or start of use.	
3.	<p>PBD030 - STOP WORK - RESOURCES FOUND If, during the course of construction, cultural, archaeological, historical or paleontological resources are uncovered at the site (surface or subsurface resources) work shall be halted immediately within 50 meters (165 feet) of the find until a qualified professional archaeologist can evaluate it. The Monterey County RMA - Planning Department and a qualified archaeologist (i.e., an archaeologist registered with the Society of Professional Archaeologists) shall be immediately contacted by the responsible individual present on-site. When contacted, the project planner and the archaeologist shall immediately visit the site to determine the extent of the resources and to develop proper mitigation measures required for the discovery. (RMA - Planning Department)</p>	Stop work within 50 meters (165 feet) of uncovered resource and contact the Monterey County RMA - Planning Department and a qualified archaeologist immediately if cultural, archaeological, historical or paleontological resources are uncovered. When contacted, the project planner and the archaeologist shall immediately visit the site to determine the extent of the resources and to develop proper mitigation measures required for the discovery.	Owner/ Applicant/ Archaeologist	Ongoing	
4.	<p>PBD013(A) - GEOTECHNICAL CERTIFICATION Prior to final inspection, the geotechnical consultant shall provide certification that all development has been constructed in accordance with the geotechnical report. (RMA - Planning Department)</p>	Submit certification by the geotechnical consultant to PBI showing project's compliance with the geotechnical report.	Owner/ Applicant/ Geotechnical Consultant	Prior to Final Building Inspection	

5.	<p>PBD014 - GRADING-WINTER RESTRICTION No land clearing or grading shall occur on the subject parcel between October 15 and April 15 unless authorized by the Director of Planning and Building Inspection. (RMA - Planning Department)</p>	None	Owner/ Applicant	Ongoing	
6.	<p>PBD016 - INDEMNIFICATION AGREEMENT The property owner agrees as a condition and in consideration of the approval of this discretionary development permit that it will, pursuant to agreement and/or statutory provisions as applicable, including but not limited to Government Code Section 66474.9, defend, indemnify and hold harmless the County of Monterey or its agents, officers and employees from any claim, action or proceeding against the County or its agents, officers or employees to attack, set aside, void or annul this approval, which action is brought within the time period provided for under law, including but not limited to, Government Code Section 66499.37, as applicable. The property owner will reimburse the county for any court costs and attorney's fees, which the County may be required by a court to pay as a result of such action. County may, at its sole discretion, participate in the defense of such action; but such participation shall not relieve applicant of his obligations under this condition. An agreement to this effect shall be recorded upon demand of County Counsel or concurrent with the issuance of building permits, use of the property, filing of the final map, whichever occurs first and as applicable. The County shall promptly notify the property owner of any such claim, action or proceeding and the County shall cooperate fully in the defense thereof. If the County fails to promptly notify the property owner of any such claim, action or proceeding or fails to cooperate fully in the defense thereof, the property owner shall not thereafter be responsible to defend, indemnify or hold the county harmless. (RMA - Planning Department)</p>	Proof of recordation of the Indemnification Agreement, as outlined, shall be submitted to PBI.	Owner/ Applicant	Upon demand of County Counsel or concurrent with the issuance of building permits, use of the property, filing of the final map, whichever occurs first and as applicable	

7.	<p>PBD018(A) - LANDSCAPE PLAN AND MAINTENANCE (SINGLE FAMILY DWELLING ONLY)</p> <p>The site shall be landscaped. At least 60 days prior to occupancy, three (3) copies of a landscaping plan shall be submitted to the Director of Planning and Building Inspection for approval. A landscape plan review fee is required for this project. Fees shall be paid at the time of landscape plan submittal. The landscaping plan shall be in sufficient detail to identify the location, species, and size of the proposed landscaping materials and shall be accompanied by a nursery or contractor's estimate of the cost of installation of the plan. Before occupancy, landscaping shall be either installed or a certificate of deposit or other form of surety made payable to Monterey County for that cost estimate shall be submitted to the Monterey County RMA - Planning Department. All landscaped areas and fences shall be continuously maintained by the applicant; all plant material shall be continuously maintained in a litter-free, weed-free, healthy, growing condition. (RMA - Planning Department)</p>	Submit landscape plans and contractor's estimate to PBI for review and approval.	Owner/ Applicant/ Contractor	At least 60 days prior to final inspection or occupancy	
		All landscaped areas and fences shall be continuously maintained by the applicant; all plant material shall be continuously maintained in a litter-free, weed-free, healthy, growing condition.	Owner/ Applicant	Ongoing	
8.	<p>PBD021 - LIGHTING - EXTERIOR LIGHTING PLAN</p> <p>All exterior lighting shall be unobtrusive, harmonious with the local area, and constructed or located so that only the intended area is illuminated and off-site glare is fully controlled. The applicant shall submit 3 copies of an exterior lighting plan, which shall indicate the location, type, and wattage of all light fixtures and include catalog sheets for each fixture. The exterior lighting plan shall be subject to approval by the Monterey County RMA - Planning Department, prior to the issuance of building permits. (RMA - Planning Department)</p>	Submit three copies of the lighting plans to PBI for review and approval.	Owner/ Applicant	Prior to issuance of building permits.	
		Construct and maintain lighting according to approved plan.	Owner/ Applicant	Ongoing	

9.		<p>PBD022 - MITIGATION MONITORING PROGRAM The applicant shall enter into an agreement with the County to implement a Mitigation Monitoring and/or Reporting Plan in accordance with Section 21081.6 of the California Public Resources Code and Section 15097 of Title 14, Chapter 3 of the California Code of Regulations. Compliance with the fee schedule adopted by the Board of Supervisors for mitigation monitoring shall be required and payment made to the County of Monterey at the time the property owner submits the signed mitigation monitoring agreement. (RMA - Planning Department)</p>	<ol style="list-style-type: none"> 1) Enter into agreement with the County to implement a Mitigation Monitoring Program. 2) Fees shall be submitted at the time the property owner submits the signed mitigation monitoring agreement. 	Owner/ Applicant	Within 60 days after project approval or prior to issuance of grading and building permits, whichever occurs first.	
10.		<p>PBD012 - FISH AND GAME FEE-NEG DEC Pursuant to the State Public Resources Code, State Fish and Game Code, and California Code of Regulations, the applicant shall pay a fee, to be collected by the County, within five (5) working days of project approval. This fee shall be paid before the Notice of Determination is filed. If the fee is not paid within five (5) working days, the project shall not be operative, vested or final until the filing fees are paid. (RMA - Planning Department)</p>	<p>The applicant shall submit a check, payable to the <i>County of Monterey</i>, to the Director of Planning and Building Inspection.</p>	Owner/ Applicant	Within 5 working days of project approval.	
			<p>If the fee is not paid within five (5) working days, the applicant shall submit a check, payable to the <i>County of Monterey</i>, to the Director of Planning and Building Inspection.</p>	Owner/ Applicant	Prior to the recordation of the final map, the start of use or the issuance of building or grading permits	
11.		<p>PBD026 – NOTICE OF REPORT Prior to issuance of building or grading permits, a notice shall be recorded with the Monterey County Recorder which states: "A Biological Assessment has been prepared for this parcel by Rana Creek Habitat Restoration, Carmel Valley, CA, dated May 31, 2006 and</p>	<p>Proof of recordation of this notice shall be furnished to PBI.</p>	Owner/ Applicant	Prior to issuance of grading and building	

		is on record at the Monterey County RMA – Planning Department, Library No. LIB060300. All development shall be in accordance with this report." (RMA - Planning Department)			permits	
12.		PBD026 – NOTICE OF REPORT Prior to issuance of building or grading permits, a notice shall be recorded with the Monterey County Recorder which states: "A Forest Management Plan has been prepared for this parcel by Matt Horowitz, Forest City Consulting, Carmel, CA, dated June 6, 2006 and is on record at the Monterey County RMA – Planning Department, Library No. LIB060299. All development shall be in accordance with this report." (RMA - Planning Department)	Proof of recordation of this notice shall be furnished to PBI.	Owner/ Applicant	Prior to issuance of grading and building permits	
13.		PBD026 – NOTICE OF REPORT Prior to issuance of building or grading permits, a notice shall be recorded with the Monterey County Recorder which states: "A Geotechnical Soils-Foundation and Geoseismic Report has been prepared for this parcel by Grice Engineering and Geology Inc., Salinas, CA, dated September 2005 and is on record in the Monterey County RMA – Planning Department, Library No. LIB060301. All development shall be in accordance with this report." (RMA - Planning Department)	Proof of recordation of this notice shall be furnished to PBI.	Owner/ Applicant	Prior to issuance of grading and building permits	
14.		PBD028 - RESTORATION OF NATURAL MATERIALS Upon completion of the development, the area disturbed shall be restored to a condition to correspond with the adjoining area, subject to the approval of the Director of Planning and Building Inspection. Plans for such restoration shall be submitted to and approved by the Director of Planning and Building Inspection prior to commencement of use. (RMA - Planning Department)	Submit restoration plans to PBI for review and approval.	Owner/ Applicant	Prior to start of use.	
15.		PBD032(A) - TREE PROTECTION Trees which are located close to the construction site(s) shall be protected from inadvertent damage from construction equipment by wrapping trunks with	Submit evidence of tree protection to PBI for review and approval.	Owner/ Applicant	Prior to issuance of grading	

		protective materials, avoiding fill of any type against the base of the trunks and avoiding an increase in soil depth at the feeding zone or drip line of the retained trees. Said protection shall be demonstrated prior to issuance of building permits subject to the approval of the Director of Planning and Building Inspection. (RMA - Planning Department)			and building permits	
16.		PBD032(B) – TREE AND ROOT PROTECTION Trees which are located close to the construction site(s) shall be protected from inadvertent damage from construction equipment by fencing off the canopy driplines and/or critical root zones (whichever is greater) with protective materials, wrapping trunks with protective materials, avoiding fill of any type against the base of the trunks and avoiding an increase in soil depth at the feeding zone or drip-line of the retained trees. Said protection shall be demonstrated prior to issuance of building permits subject to the approval of the Monterey County RMA - Planning Department. (RMA - Planning Department)	Submit evidence of tree protection to PBI for review and approval.	Owner/ Applicant	Prior to Issuance of Grading and/or Building Permits	
17.		PBD034 - UTILITIES - UNDERGROUND All new utility and distribution lines shall be placed underground. (RMA - Planning Department; Public Works)	None	Applicant/ Owner	Ongoing	
18.		PBD036 - WATER TANK APPROVAL The water tank shall be painted an earth tone color to blend into the area and landscaped (including land sculpturing and fencing, where appropriate), subject to the approval of the Monterey County RMA - Planning Department, prior to the issuance of building permits. (RMA - Planning Department)	1) Submit proposed color of water tank and landscaping to PBI for review and approval. 2) Provide evidence to PBI that the water tank is painted as approved by PBI and that landscaped was installed as approved by PBI.	Applicant/ Owner Applicant/ Owner	Prior to the issuance of grading and building permits Prior to final inspection / occupancy	
19.		FIRE002 - ROADWAY ENGINEERING The grade for all roads shall not exceed 15 percent. Where road grades exceed 8 percent, a minimum structural roadway surface of 0.17 feet of asphaltic	Applicant shall incorporate specification into design and enumerate as "Fire Dept. Notes" on plans.	Applicant or owner	Prior to issuance of grading and/or	

		concrete on 0.34 feet of aggregate base shall be required. The length of vertical curves in roadways, exclusive of gutters, ditches and drainage structures designed to hold or divert water, shall not be less than 100 feet. No roadway turn shall have a horizontal inside radius of less than 50 feet. A roadway turn radius of 50 to 100 feet is required to have an additional 4 feet of roadway surface. A roadway turn radius of 100 to 200 feet is required to have an additional 2 feet of roadway surface. Roadway turnarounds shall be required on dead-end roads in excess of 150 feet of surface length. The minimum turning radius for a turnaround shall be 40 feet from the center line of the road. If a hammerhead/T is used, the top of the "T" shall be a minimum of 60 feet in length. (Cachagua Fire Protection District)			building permit.	
			Applicant shall schedule fire dept. clearance inspection for each phase of development.	Applicant or owner	Prior to final building inspection	
20.		FIRE007 - DRIVEWAYS Driveways shall not be less than 12 feet wide unobstructed, with an unobstructed vertical clearance of not less than 15 feet. The grade for all driveways shall not exceed 15 percent. Where the grade exceeds 8 percent, a minimum structural roadway surface of 0.17 feet of asphaltic concrete on 0.34 feet of aggregate base shall be required. The driveway surface shall be capable of supporting the imposed load of fire apparatus (22 tons), and be accessible by conventional-drive vehicles, including sedans. For driveways with turns 90 degrees and less, the minimum horizontal inside radius of curvature shall be 25 feet. For driveways with turns greater than 90 degrees, the minimum horizontal inside radius curvature shall be 28 feet. For all driveway turns, an additional surface of 4 feet shall be added. All driveways exceeding 150 feet in length, but less than 800 feet in length, shall provide a turnout near the midpoint of the driveway. Where the driveway exceeds 800 feet, turnouts shall be provided at no greater than 400-foot intervals. Turnouts shall be a minimum of 12 feet wide and 30 feet long with a minimum of 25-foot taper at both ends. Turnarounds shall be required on driveways in	Applicant shall incorporate specification into design and enumerate as "Fire Dept. Notes" on plans.	Applicant or owner	Prior to issuance of grading and/or building permit.	
			Applicant shall schedule fire dept. clearance inspection	Applicant or owner	Prior to final building inspection	

		excess of 150 feet of surface length and shall long with a minimum 25-foot taper at both ends. Turnarounds shall be required on driveways in excess of 150 feet of surface length and shall be located within 50 feet of the primary building. The minimum turning radius for a turnaround shall be 40 feet from the centerline of the driveway. If a hammerhead/T is used, the top of the "T" shall be a minimum of 60 feet in length. (Cachagua Fire Protection District)				
21.		FIRE008 - GATES All gates providing access from a road to a driveway shall be located at least 30 feet from the roadway and shall open to allow a vehicle to stop without obstructing traffic on the road. Gate entrances shall be at least the width of the traffic lane but in no case less than 12 feet wide. Where a one-way road with a single traffic lane provides access to a gated entrance, a 40-foot turning radius shall be used. Where gates are to be locked, the installation of a key box or other acceptable means for immediate access by emergency equipment may be required. (Cachagua Fire Protection District)	Applicant shall incorporate specification into design and enumerate as "Fire Dept. Notes" on plans.	Applicant or owner	Prior to issuance of grading and/or building permit.	
			Applicant shall schedule fire dept. clearance inspection	Applicant or owner	Prior to final building inspection	
22.		FIRE009 - BRIDGES All new and reconstructed bridges shall be at least the width of the roadbed and berms, but in no case less than 12 feet wide. Bridge width on all roads exceeding tertiary standards shall not be less than the width of the two lanes with berms. All bridges shall be designed for HS15-44 loading and have guardrails. Appropriate signage, including but not limited to, weight ratings or vertical clearance limitations, and one-way road or single-lane road conditions, shall be provided at both entrances to any bridge. One-lane bridges may be permitted if there is unobstructed visibility across the entire bridge, and turnouts are provided at both bridge ends. The fire authority may impose more stringent requirements for bridges. (Cachagua Fire Protection District)	Applicant shall incorporate specification into design and enumerate as "Fire Dept. Notes" on plans.	Applicant or owner	Prior to issuance of grading and/or building permit.	
			Applicant shall schedule fire dept. clearance inspection	Applicant or owner	Prior to final building inspection	

23.	<p>FIRE011 - ADDRESSES FOR BUILDINGS All buildings shall be issued an address in accordance with Monterey County Ordinance No. 1241. Each occupancy, except accessory buildings, shall have its own permanently posted address. When multiple occupancies exist within a single building, each individual occupancy shall be separately identified by its own address. Letters, numbers, and symbols for addresses shall be a minimum of 4-inch height, 1/2-inch stroke, contrasting with the background color of the sign, and shall be Arabic. The sign and numbers shall be reflective and made of a noncombustible material. Address signs shall be placed at each driveway entrance and at each driveway split. Address signs shall be and visible from both directions of travel along the road. In all cases, the address shall be posted at the beginning of construction and shall be maintained thereafter. Address signs along one-way roads shall be visible from both directions of travel. Where multiple addresses are required at a single driveway, they shall be mounted on a single sign. Where a roadway provides access solely to a single commercial occupancy, the address sign shall be placed at the nearest road intersection providing access to that site. Permanent address numbers shall be posted prior to requesting final clearance. (Cachagua Fire Protection District)</p>	<p>Applicant shall incorporate specification into design and enumerate as "Fire Dept. Notes" on plans.</p>	Applicant or owner	Prior to issuance of building permit.	
		<p>Applicant shall schedule fire dept. clearance inspection</p>	Applicant or owner	Prior to final building inspection	
24.	<p>FIRE014 - EMERGENCY WATER STANDARDS - FIRE PROTECTION WATER SUPPLY - (SINGLE PARCEL) For development of structures totaling less than 3,000 square feet on a single parcel, the minimum fire protection water supply shall be 4,900 gallons. For development of structures totaling 3,000 square feet or more on a single parcel, the minimum fire protection water supply shall be 9,800 gallons. For development of structures totaling more than 10,000 square feet on a single parcel, the reviewing authority may require additional fire protection water supply. Other water supply alternatives, including ISO Rural Class 8 mobile</p>	<p>Applicant shall incorporate specification into design and enumerate as "Fire Dept. Notes" on plans.</p>	Applicant or owner	Prior to issuance of grading and/or building permit.	
		<p>Applicant shall schedule fire dept. clearance inspection</p>	Applicant or owner	Prior to final building inspection	

		water systems, may be permitted by the fire authority to provide for the same practical effect. The quantity of water required by this condition shall be in addition to the domestic demand and shall be permanently and immediately available. (Cachagua Fire Protection District)				
25.		FIRE015 - FIRE HYDRANTS/FIRE VALVES A fire hydrant or fire valve is required. The hydrant or fire valve shall be 18 inches above grade, 8 feet from flammable vegetation, no closer than 4 feet nor further than 12 feet from a roadway, and in a location where fire apparatus using it will not block the roadway. The hydrant serving any building shall be not less than 50 feet and not more than 1000 feet by road from the building it is to serve. Minimum hydrant standards shall include a brass head and valve with at least one 2 1/2 inch National Hose outlet supplied by a minimum 4 inch main and riser. More restrictive hydrant requirements may be applied by the Reviewing Authority. Each hydrant/valve shall be identified with a reflectorized blue marker, with minimum dimensions of 3 inches, located on the driveway address sign, non-combustible post or fire hydrant riser. If used, the post shall be within 3 feet of the hydrant/valve, with the blue marker not less than 3 feet or greater than 5 feet above the ground, visible from the driveway. On paved roads or driveways, reflectorized blue markers shall be permitted to be installed in accordance with the State Fire Marshal's Guidelines for Fire Hydrant Markings Along State Highways and Freeways, May 1988. (Cachagua Fire Protection District)	Applicant shall incorporate specification into design and enumerate as "Fire Dept. Notes" on plans.	Applicant or owner	Prior to issuance of grading and/or building permit.	
			Applicant shall schedule fire dept. clearance inspection	Applicant or owner	Prior to final building inspection	
26.		FIRE017 - DISPOSAL OF VEGETATION AND FUELS Disposal, including chipping, burying, or removal to a landfill site approved by the local jurisdiction, of vegetation and debris caused by site development and construction, road and driveway construction, and fuel modification shall be completed prior to final clearance of	Applicant shall schedule fire dept. clearance inspection	Applicant or owner	Prior to final building inspection	

		the related permit. (Cachagua Fire Protection District)				
27.		FIRE020 - DEFENSIBLE SPACE REQUIREMENTS (HAZARDOUS CONDITIONS) Remove combustible vegetation from within a minimum of 30 feet of structures. Limb trees 6 feet up from ground. Remove limbs within 10 feet of chimneys. Additional fire protection or firebreaks approved by the Reviewing Authority may be required to provide reasonable fire safety. Environmentally sensitive areas may require alternative fire protection, to be determined by Reviewing Authority and the Director of Planning and Building Inspection. (Cachagua Fire Protection District)	Applicant shall incorporate specification into design and enumerate as "Fire Dept. Notes" on plans.	Applicant or owner	Prior to issuance of grading and/or building permit.	
			Applicant shall schedule fire dept. clearance inspection	Applicant or owner	Prior to final building inspection	
28.		FIRE021 - FIRE PROTECTION EQUIPMENT & SYSTEMS - FIRE SPRINKLER SYSTEM (STANDARD) The building(s) and attached garage(s) shall be fully protected with automatic fire sprinkler system(s). Installation shall be in accordance with the applicable NFPA standard. A minimum of four (4) sets of plans for fire sprinkler systems must be submitted by a California licensed C-16 contractor and approved prior to installation. This requirement is not intended to delay issuance of a building permit. A rough sprinkler inspection must be scheduled by the installing contractor and completed prior to requesting a framing inspection. (Cachagua Fire Protection District)	Applicant shall enumerate as "Fire Dept. Notes" on plans.	Applicant or owner	Prior to issuance of building permit.	
			Applicant shall schedule fire dept. rough sprinkler inspection	Applicant or owner	Prior to framing inspection	
			Applicant shall schedule fire dept. final sprinkler inspection	Applicant or owner	Prior to final building inspection	
29.		FIRE025 - SMOKE ALARMS – (SINGLE FAMILY DWELLING) Where a household fire warning system or combination fire/burglar alarm system is installed in lieu of single-station smoke alarms required by the Uniform Building Code the alarm panel shall be required to be placarded as permanent building equipment. (Cachagua Fire Protection District)	Applicant shall enumerate as "Fire Dept. Notes" on plans.	Applicant or owner	Prior to issuance of building permit.	
			Applicant shall schedule fire alarm system acceptance test.	Applicant or owner	Prior to final building inspection	

30.		<p>FIRE027 - ROOF CONSTRUCTION - (VERY HIGH HAZARD SEVERITY ZONE) All new structures, and all existing structures receiving new roofing over 50 percent or more of the existing roof surface within a one-year period, shall require a minimum of ICBO Class A roof construction. (Cachagua Fire Protection District)</p>	Applicant shall enumerate as "Fire Dept. Notes" on plans.	Applicant or owner	Prior to issuance of building permit.	
31.		<p>PW0006 – CARMEL VALLEY The Applicant shall pay the Carmel Valley Master Plan Area Traffic Mitigation fee pursuant to the Board of Supervisors Resolution NO. 95-140, adopted September 12, 1995 (Fees are updated annually based on CCI). (Public Works)</p>	Applicant shall pay to PBI the required traffic mitigation fee.	Owner/ Applicant	Prior to Building Permits Issuance	
32.		<p>WR40 - WATER CONSERVATION MEASURES The applicant shall comply with Ordinance No. 3932, or as subsequently amended, of the Monterey County Water Resources Agency pertaining to mandatory water conservation regulations. The regulations for new construction require, but are not limited to: a. All toilets shall be ultra-low flush toilets with a maximum tank size or flush capacity of 1.6 gallons, all shower heads shall have a maximum flow capacity of 2.5 gallons per minute, and all hot water faucets that have more than ten feet of pipe between the faucet and the hot water heater serving such faucet shall be equipped with a hot water recirculating system. b. Landscape plans shall apply xeriscape principles, including such techniques and materials as native or low water use plants and low precipitation sprinkler heads, bubblers, drip irrigation systems, and timing devices. (Water Resources Agency)</p>	Compliance to be verified by building inspector at final inspection.	Owner/ Applicant	Prior to final building inspection / occupancy	

MITIGATION MEASURES

33.	1	MM1 – BAT SURVEY A qualified biologist shall survey large trees proposed for removal to determine the presence or absence of bats. (RMA - Planning Department)	A qualified biologist shall submit a report summarizing their findings and/or actions to the Director of Planning. If no bats are found, then no further action is required.	Applicant	Prior to site disturbance and and/or the use of heavy equipment to clear the site
			In the event that bats are found in these trees, the biological survey shall provide a list of proposed mitigations necessary to protect bat species.	Applicant	Prior to site disturbance and and/or the use of heavy equipment to clear the site
34.	2	MM2 – DUSKY FOOTED WOODRAT Prior to site disturbance and/or the use of heavy equipment to clear the site a qualified biologist shall survey and identify Woodrat nests found within the building envelope and oversee the dismantling by hand to allow the Woodrats to find new homes outside the building envelopes. (RMA - Planning Department)	A qualified biologist shall submit to the Director of Planning a statement of findings and actions taken as appropriate.	Applicant	Within 30 days prior to site disturbance
35.	3	MM3 – NESTING RAPTORS SURVEY The applicant shall remove trees only during the fall and after August 1st. If tree removal is to occur between February and August, a qualified biologist shall survey large trees proposed for removal for the presence or absence of any potentially breeding birds nesting. If nesting birds are not found, no further	A qualified biologist shall submit a report summarizing their findings and/or actions to the Director of Planning. If no raptors are found, then no further action is required.	Applicant	Prior to site disturbance and prior to the issuance of grading and building permits

		action would be necessary. (RMA - Planning Department)	In the event that raptors are found using these trees, the biological survey shall provide a list of proposed mitigations necessary to protect the raptors.	Applicant	Prior to site disturbance and prior to the issuance of grading and building permits	
36.	4	<p>MM4 - EROSION CONTROL PLAN AND SCHEDULE</p> <p>The approved development shall incorporate the recommendations of the Erosion Control Plan as reviewed by the Soils Conservation Service and the Director of RMA - Planning Department. The applicant shall submit an erosion control plan and maintenance schedule to prevent potential erosion from draining into the Tassajara Creek. Stormwater runoff shall be managed on all impervious surfaces to mitigate the impacts of erosion from a fifty-year flood. All cut and/or fill slopes exposed during the course of construction be covered, seeded, or otherwise treated to control erosion during the course of construction, subject to the approval of the Monterey County RMA - Planning Department. The improvement and grading plans shall include an implementation schedule of measures for the prevention and control of erosion, siltation, and dust during and immediately following construction and until erosion control planting becomes established. This program shall be approved by the Director of Planning and Building Inspection. (RMA - Planning Department)</p>	<p>1) Evidence of compliance with the Erosion Control Plan shall be submitted to PBI prior to issuance of building and grading permits.</p> <p>2) Evidence of compliance with the Implementation Schedule shall be submitted to PBI during the course of construction until project completion as approved by the Director of PBI.</p>	Owner/ Applicant	Prior to Issuance of Grading and Building Permits	
				Owner/ Applicant	Prior to Final Inspection	

37.	5	<p>MM5 – OAK WOODLAND REVEGETATION The applicant shall not plant any vegetation under the canopy of existing large oak trees to promote native regeneration. Replanting or replacement is not a requirement of this project; however if oak trees are planted within the building envelope they shall not be planted within the driplines of a native mature oaks. No fill shall be placed within the dripline of any oak tree. The applicant shall not remove young trees and control invasive vegetation. The applicant shall not remove any oak tree for the purposes of creating defensible space. (RMA - Planning Department)</p>	None	Applicant	Ongoing	
-----	---	--	------	-----------	---------	--

END OF CONDITIONS

WORK
 IN FRONT OF HOME DEPOT AND HOME DEPOT SUPPLY REQUIREMENTS
 LAM

1. SLOPE SHALL BE INSTALLED AS SHOWN
 FROM WHEN THE DRAINAGE DITCHES SHALL BE INSTALLED TO
 THE EXISTING FLOOR FINISH OF FUTURE FLOORING.

2. SLOPE SHALL BE INSTALLED AS SHOWN
 FROM WHEN THE DRAINAGE DITCHES SHALL BE INSTALLED TO
 THE EXISTING FLOOR FINISH OF FUTURE FLOORING.

3. SLOPE SHALL BE INSTALLED AS SHOWN
 FROM WHEN THE DRAINAGE DITCHES SHALL BE INSTALLED TO
 THE EXISTING FLOOR FINISH OF FUTURE FLOORING.

4. SLOPE SHALL BE INSTALLED AS SHOWN
 FROM WHEN THE DRAINAGE DITCHES SHALL BE INSTALLED TO
 THE EXISTING FLOOR FINISH OF FUTURE FLOORING.

5. SLOPE SHALL BE INSTALLED AS SHOWN
 FROM WHEN THE DRAINAGE DITCHES SHALL BE INSTALLED TO
 THE EXISTING FLOOR FINISH OF FUTURE FLOORING.

6. SLOPE SHALL BE INSTALLED AS SHOWN
 FROM WHEN THE DRAINAGE DITCHES SHALL BE INSTALLED TO
 THE EXISTING FLOOR FINISH OF FUTURE FLOORING.

7. SLOPE SHALL BE INSTALLED AS SHOWN
 FROM WHEN THE DRAINAGE DITCHES SHALL BE INSTALLED TO
 THE EXISTING FLOOR FINISH OF FUTURE FLOORING.

8. SLOPE SHALL BE INSTALLED AS SHOWN
 FROM WHEN THE DRAINAGE DITCHES SHALL BE INSTALLED TO
 THE EXISTING FLOOR FINISH OF FUTURE FLOORING.

9. SLOPE SHALL BE INSTALLED AS SHOWN
 FROM WHEN THE DRAINAGE DITCHES SHALL BE INSTALLED TO
 THE EXISTING FLOOR FINISH OF FUTURE FLOORING.

10. SLOPE SHALL BE INSTALLED AS SHOWN
 FROM WHEN THE DRAINAGE DITCHES SHALL BE INSTALLED TO
 THE EXISTING FLOOR FINISH OF FUTURE FLOORING.

11. SLOPE SHALL BE INSTALLED AS SHOWN
 FROM WHEN THE DRAINAGE DITCHES SHALL BE INSTALLED TO
 THE EXISTING FLOOR FINISH OF FUTURE FLOORING.

12. SLOPE SHALL BE INSTALLED AS SHOWN
 FROM WHEN THE DRAINAGE DITCHES SHALL BE INSTALLED TO
 THE EXISTING FLOOR FINISH OF FUTURE FLOORING.

13. SLOPE SHALL BE INSTALLED AS SHOWN
 FROM WHEN THE DRAINAGE DITCHES SHALL BE INSTALLED TO
 THE EXISTING FLOOR FINISH OF FUTURE FLOORING.

14. SLOPE SHALL BE INSTALLED AS SHOWN
 FROM WHEN THE DRAINAGE DITCHES SHALL BE INSTALLED TO
 THE EXISTING FLOOR FINISH OF FUTURE FLOORING.

15. SLOPE SHALL BE INSTALLED AS SHOWN
 FROM WHEN THE DRAINAGE DITCHES SHALL BE INSTALLED TO
 THE EXISTING FLOOR FINISH OF FUTURE FLOORING.

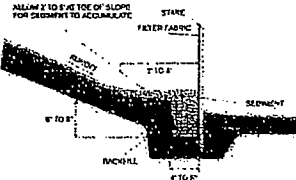

1. RECOMMENDED INSTALLATION OF SILT FENCE

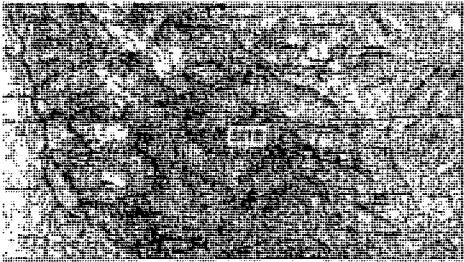
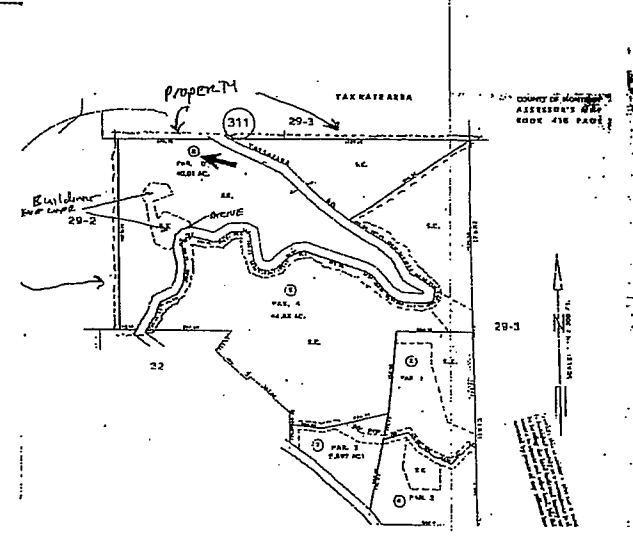
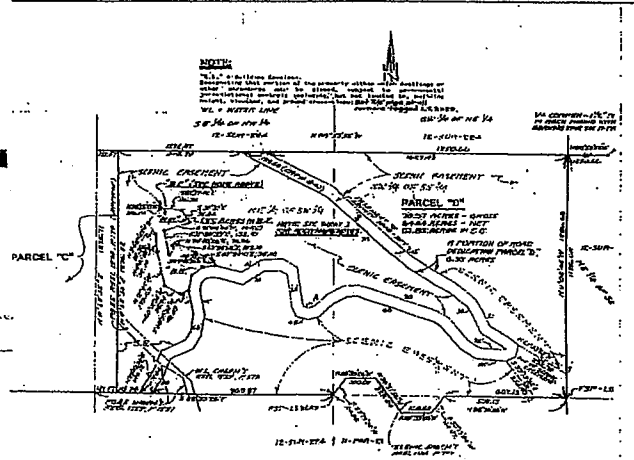

VICINITY MAP

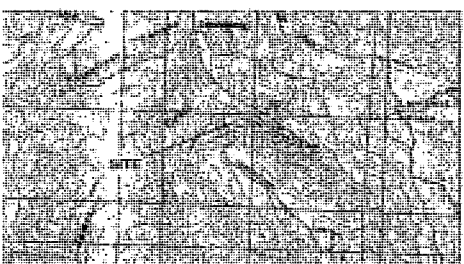

LOCATION MAP

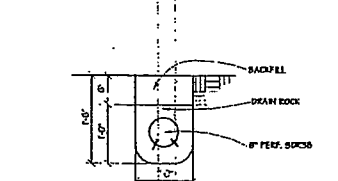
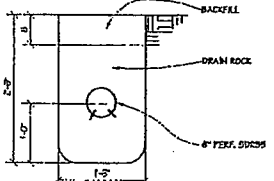
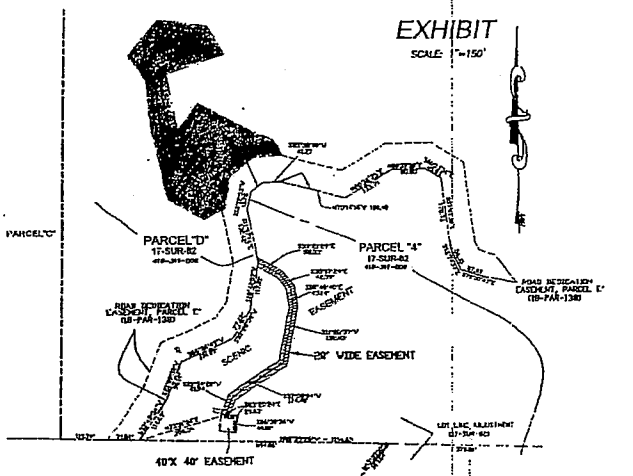
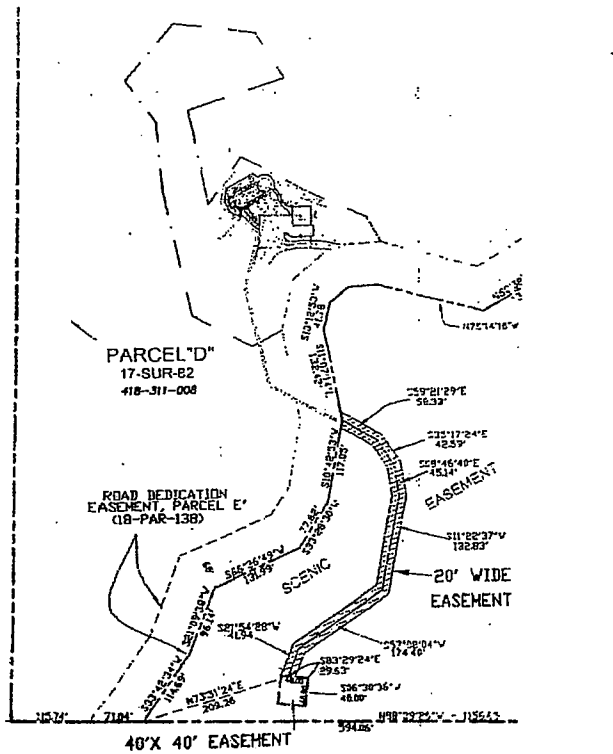

SPRINGS STUDIO
 AN J.F. MANNING
 P.O. BOX 536 HOPLAND CA 95949
 (707) 744-1011 744-1708 FAX

EXHIBIT G
 COPYRIGHT 2006 VITAL DESIGNS
 P.O. BOX 18 TALLMAGE CA, 95461

PETER 908
 7522 LELA
 SEBASTOPOL, CA 95472
 (707) 828-9062

NEW HOUSE FOR STEVEN KIRBY
 & LAURA REYNA @ TABBAJARA
 CARMEL VALLEY, CA
 A.P.N. 419-311-008

DATE
 4-2-06

PAGE:
 2.A

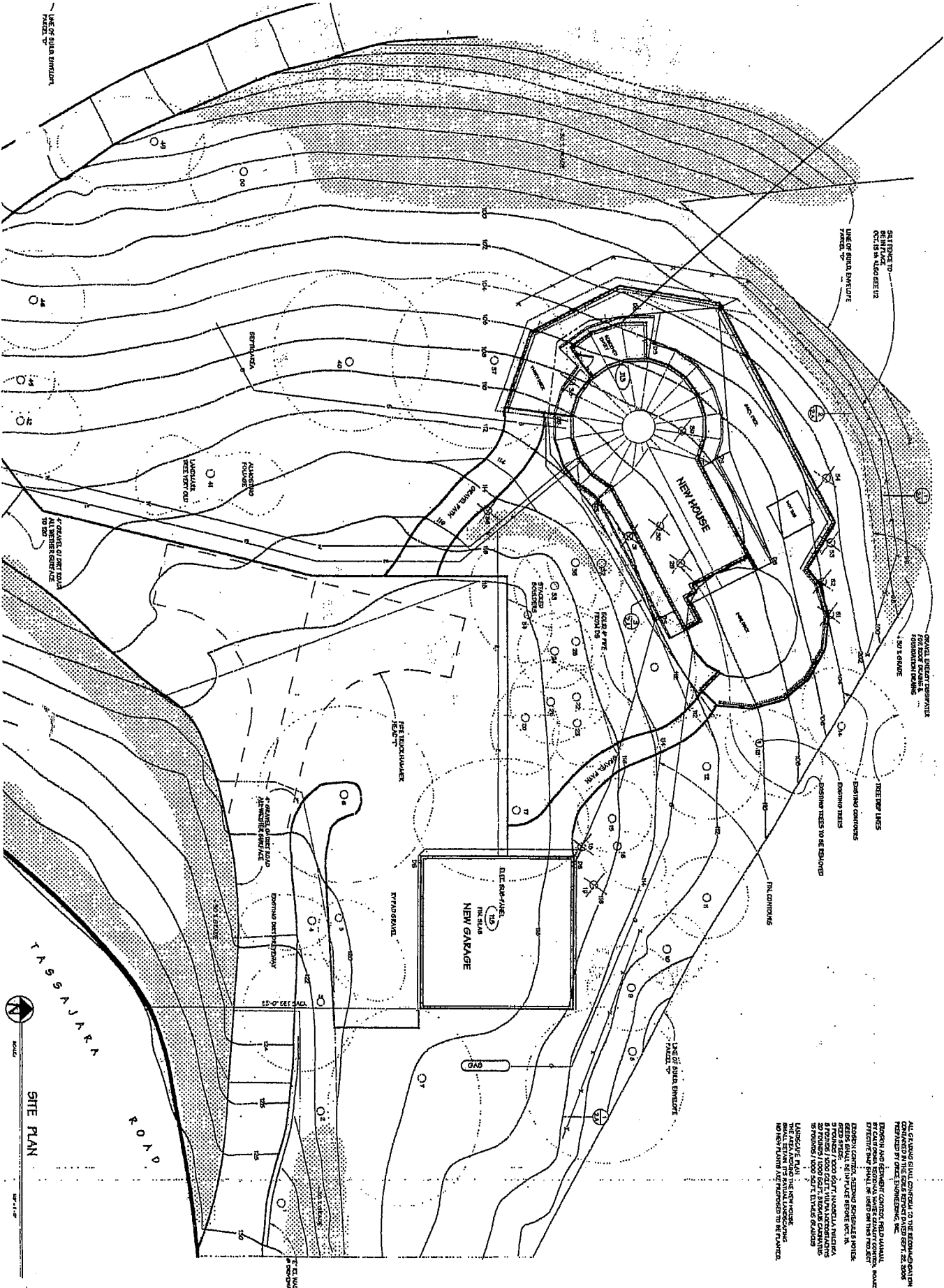

SHOWN TO
OCT 15 11 00 AM
OCT 15 11 00 AM
OCT 15 11 00 AM

SHOWN TO
OCT 15 11 00 AM
OCT 15 11 00 AM
OCT 15 11 00 AM

ALL RIGHTS RESERVED
BY CALIFORNIA REGISTERED PROFESSIONAL ENGINEER
DATE 08/15/2005
EXCEPT WHERE SHOWN OTHERWISE
THIS PLAN IS THE PROPERTY OF
VITAL DESIGN, INC. AND IS NOT TO BE
REPRODUCED OR TRANSMITTED IN ANY FORM
OR BY ANY MEANS, ELECTRONIC OR MECHANICAL,
INCLUDING PHOTOCOPYING, RECORDING, OR BY
ANY INFORMATION STORAGE AND RETRIEVAL
SYSTEM, WITHOUT PERMISSION IN WRITING
FROM VITAL DESIGN, INC.

PAGE 2	NEW HOUSE FOR: STEVEN KIRBY & LAURA REYNA @ TASSAJARA CARMEL VALLEY, CA A.P.N. 418-311-008	PETER 9CHURCH ENGINEERING 7528 LELAND STREET SEBASTOPOL, CA 95472 (707) 829-9062	DESIGNED BY DAVID RAITT 468-0876 ALL RIGHTS RESERVED COPYRIGHT 2005 VITAL DESIGN P.O. BOX 18 TALMAGE CA, 95491	OAK SPRINGS STUDIO BRIAN J.F. MANNING P.O. BOX 556 HOPLAND CA, 95449 (707) 744-1811 744-1708 FAX
------------------	---	---	---	---

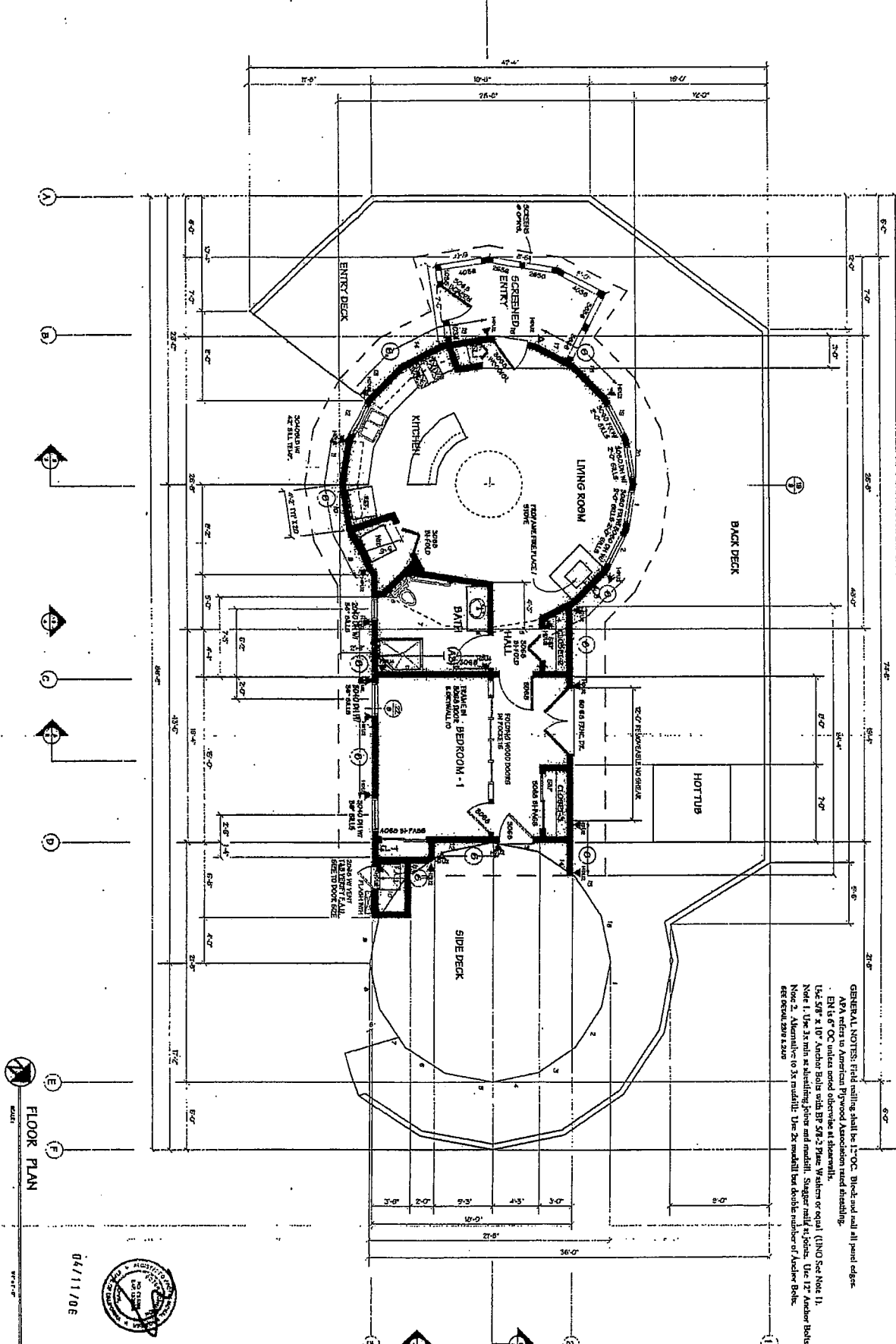

SHEAR WALL SCHEDULE

NO.	SHEATHING & EDGE WALL SPACING	FRAMING CLIP	SOFTEN/ANGLE ANCHOR	ANCHOR BOLT	TIEDOWN NUTS
6	5/8" Hardwood w/ #11 @ 6"	LS70 @ 3x4"	1" OC	4x4" OC	1/2"
A3	3/8" MIN/4x4 w/ #4 @ 3"	LS70 @ 12"	1" OC	3x3" OC	1/2"

GENERAL NOTES: Field walls shall be 12" OC. Block and wall all round edges.
 APA refers to American Plywood Association rated sheathing.
 1x4 5/8" x 10" Anchor Bolts with BP 5/8" x 2" Plates. Washers or equal. (UND Noted)
 Note 1. The 3x min is sheathing plate and nailing. Suggest nail to plate. The 12" Anchor Bolts.
 Note 2. Alternates to 3x middle. The 2x middle has double number of Anchor Bolts.
 see detail zone 2 zone

FLOOR PLAN

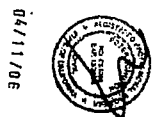

04/11/06

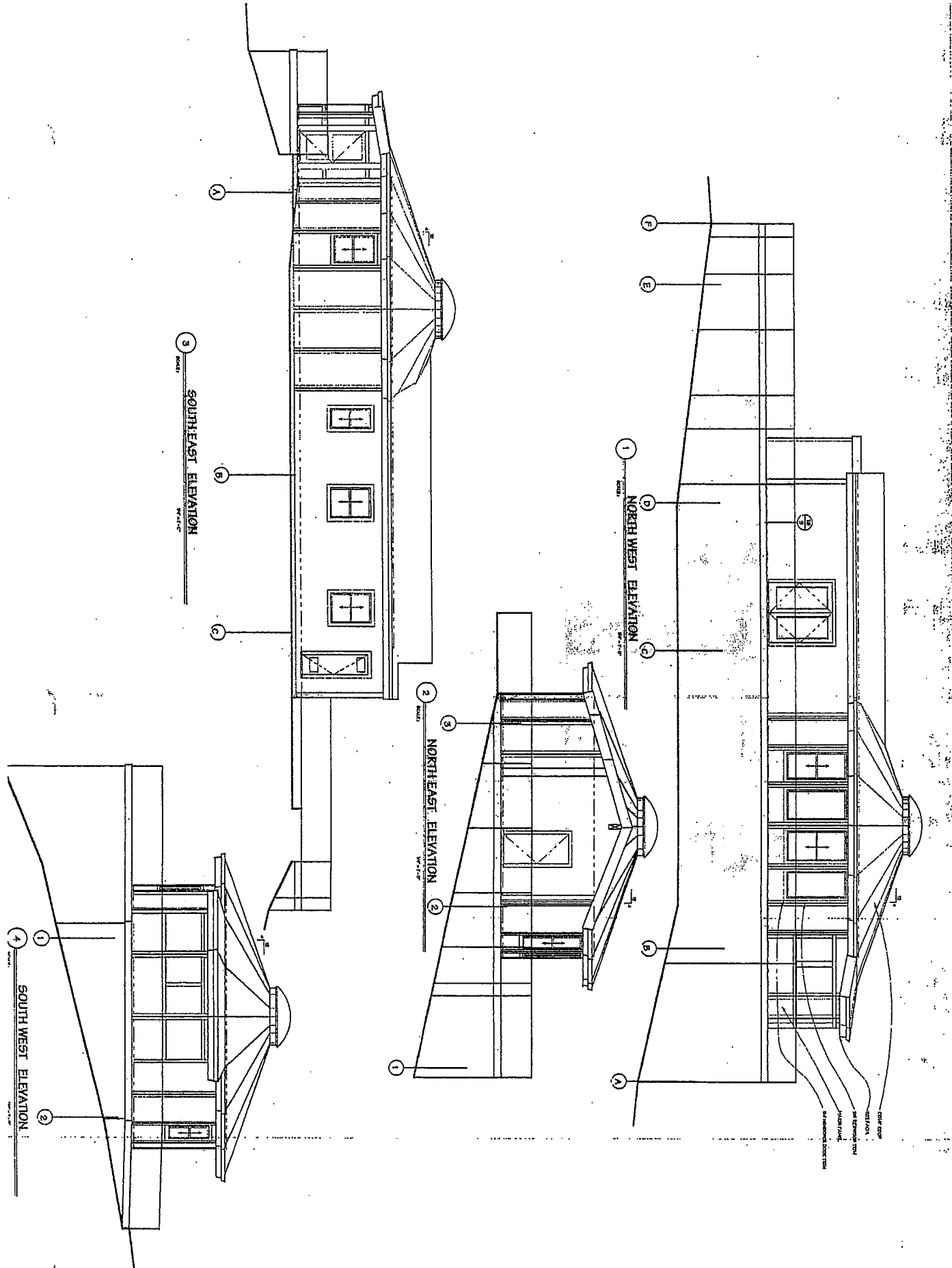

NEW HOUSE FOR: STEVEN KIRBY
 & LAURA REYNA @ TABBAJARA
 CARMEL VALLEY, CA
 A.P.N. 41B-311-00B

PETER SCHURCH ENGINEERING
 762B LELAND STREET
 SEASIDE, CA 95472
 (707) 929-9062

DESIGNED BY DAVID RAITT
 46B-0878 ALL RIGHTS RESERVED
 COPYRIGHT 2005 VITAL DESIGN
 P.O. BOX 18 TALMAGE CA, 95461

OAK SPRINGS STUDIO
 BRIAN J.F. MANNING
 P.O. BOX 535 HOPLAND CA, 95449
 (707) 744-1611 744-1708 FAX



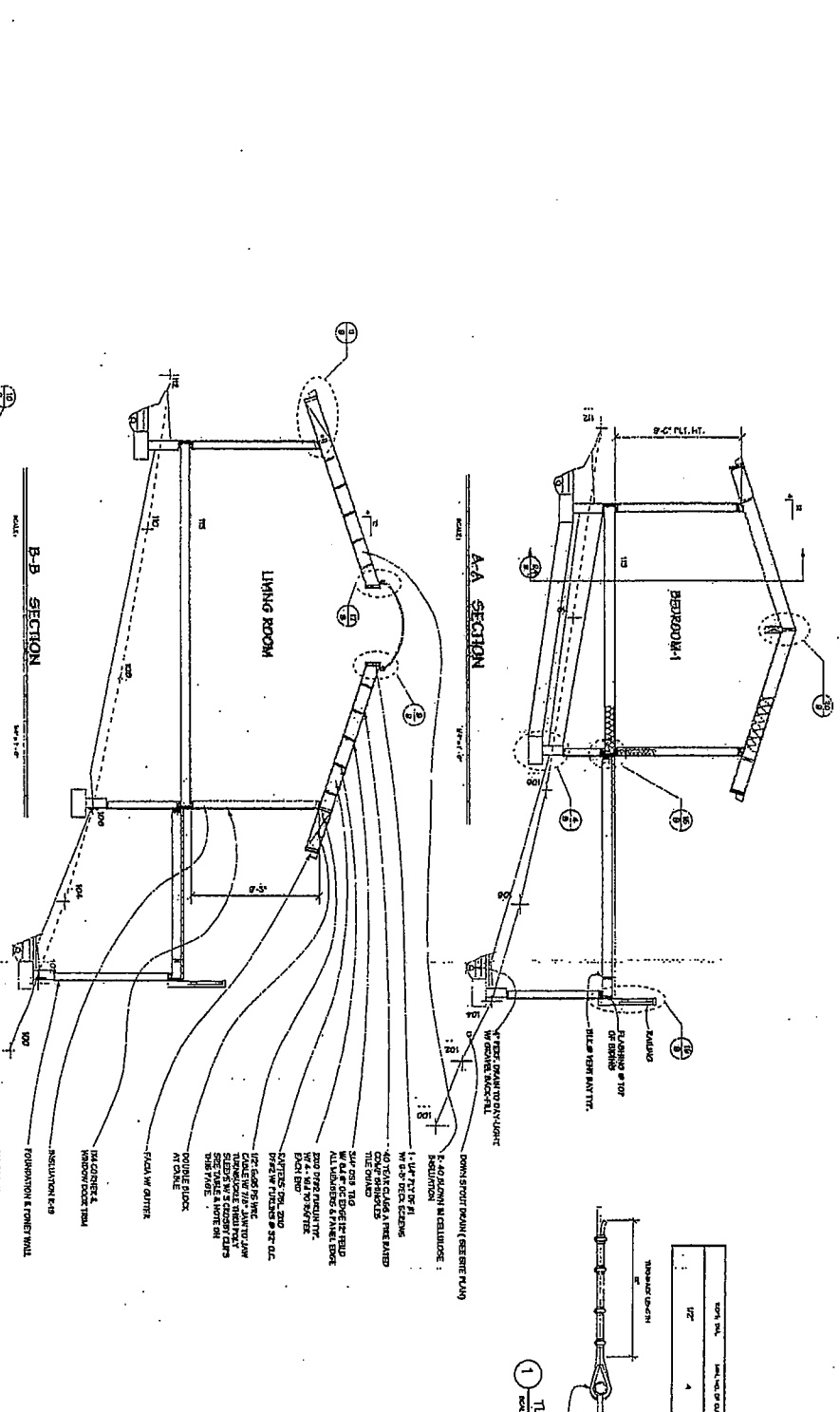
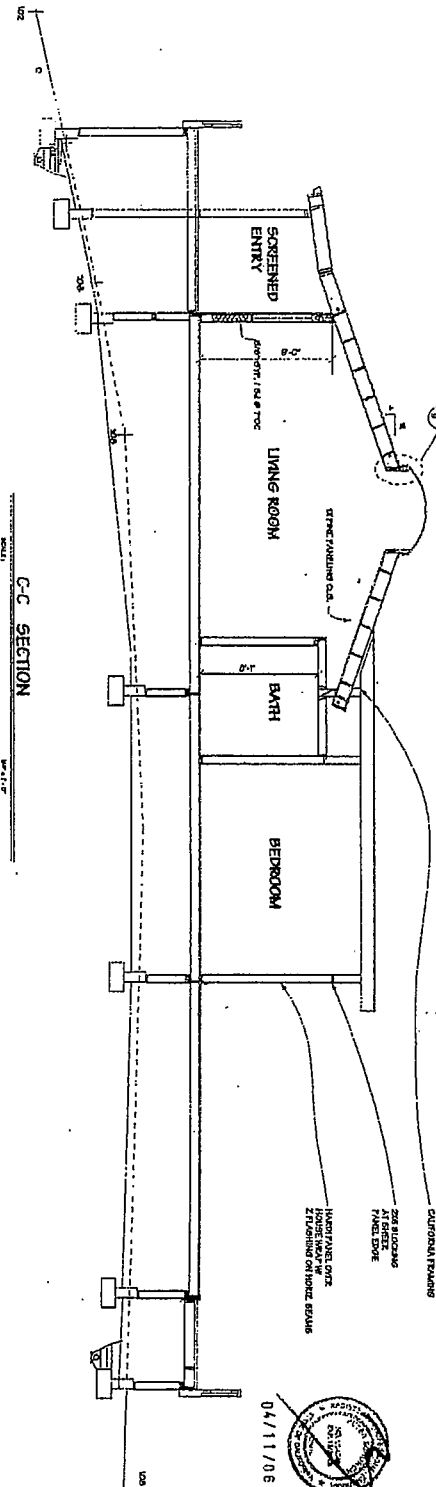

STEEL WIRE ROPE NOTES

1. ALL WIRE ROPES SHALL BE "UNDER OR OVER" ALL CABLES SHALL BE "OVER" UNLESS OTHERWISE NOTED.
2. WIRE ROPES SHALL BE "UNDER OR OVER" ALL CABLES SHALL BE "OVER" UNLESS OTHERWISE NOTED.
3. WIRE ROPES SHALL BE "UNDER OR OVER" ALL CABLES SHALL BE "OVER" UNLESS OTHERWISE NOTED.
4. WIRE ROPES SHALL BE "UNDER OR OVER" ALL CABLES SHALL BE "OVER" UNLESS OTHERWISE NOTED.
5. WIRE ROPES SHALL BE "UNDER OR OVER" ALL CABLES SHALL BE "OVER" UNLESS OTHERWISE NOTED.

TURN BUCKLE DETAIL

1/4" = 1'-0"

5	DATE	NEW HOUSE FOR: STEVEN KIRBY & LAURA REYNA @ TABAJARA CARMEL VALLEY, CA A.P.N. 418-311-008	PETER SCHURCH ENGINEERING 7525 LELAND STREET BEBASSTOPOL, CA 95472 (707) 828-8082	DESIGNED BY DAVID RAITT 468-0876 ALL RIGHTS RESERVED COPYRIGHT 2006 VITAL DESIGNS P.O. BOX 18 TALMAGE CA, 95481	OAK SPRINGS STUDIO BRIAN J.F. MANNING P.O. BOX 535 HOPLAND CA, 95449 (707) 744-1611 744 - 1708 FAX
	PAGE	4-5-08			

CACHAGUA AREA

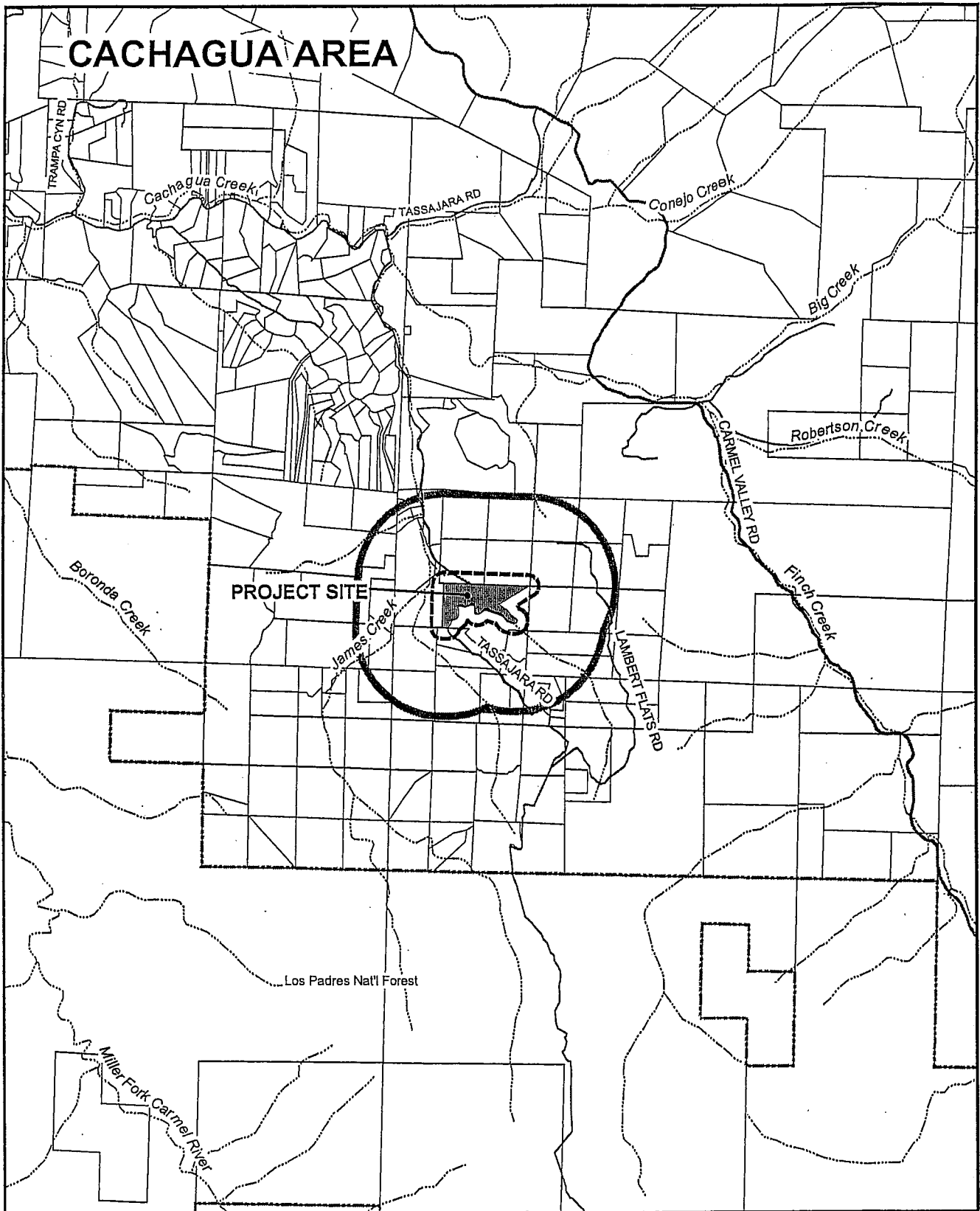

APPLICANT: KIRBY

APN: 418-311-008-000

FILE # PLN060254

300' Limit
 2500' Limit
 City Limits



PLANNER: MANUQUERRA